

UNDER

Motoriduttore interrato
Under grounded gear motor
Motoreducteur enterré
Motorreductor interrado
Unrterflur-Drehtorantrieb
Motorredutor interrado
Podziemny motoreduktor



INDEX

1	Safety warnings	p. 9
2	Product overview	p. 11
2.1	Product description	p. 11
2.2	Models and characteristics	p. 11
3	Preliminary checks	p. 11
4	Installing the product	p. 12
4.1	Installation	p. 12
4.2	Electrical connections	p. 12
4.3	Emergency unblocking	p. 12
5	Testing and commissioning	p. 13
5.1	Testing	p. 13
5.2	Commissioning	p. 13
6	Figures	p. 44
7	EC Declaration of Conformity	p. 47

1 - SAFETY WARNINGS

ATTENTION !

ORIGINAL INSTRUCTIONS - important safety instructions. Follow the instructions since incorrect installation can lead to severe injury! Save these instructions.

Read the instructions carefully before proceeding with installation.

The design and manufacture of the devices making up the product and the information in this manual are compliant with current safety standards. However, incorrect installation or programming may cause serious injury to those working on or using the system. Compliance with the instructions provided here when installing the product is therefore extremely important.

If in any doubt regarding installation, do not proceed and contact the Key Automation Technical Service for clarifications.

Under European legislation, an automatic door or gate system must comply with the standards envisaged in the Directive 2006/42/EC (Machinery Directive) and in particular standards EN 12445; EN 12453; EN 12635 and EN 13241-1, which enable declaration of presumed conformity of the automation system.

Therefore, final connection of the automation system to the electrical mains, system testing, commissioning and routine maintenance must be performed by skilled, qualified personnel, in observance of the instructions in the "Testing and commissioning the automation system" section.

The aforesaid personnel are also responsible for the tests required to verify the solutions adopted according to the risks present, and for ensuring observance of all legal provisions, standards and regulations, with particular reference to all requirements of the EN 12445 standard which establishes the test methods for testing door and gate automation systems.

ATTENTION !

Before starting installation, perform the following checks and assessments:

ensure that every device used to set up the automation system is suited to the intended system overall. For this purpose, pay special attention to the data provided in the "Technical specifications"

section. Do not proceed with installation if any one of these devices is not suitable for its intended purpose;

check that the devices purchased are sufficient to guarantee system safety and functionality;

perform a risk assessment, including a list of the essential safety requirements as envisaged in Annex I of the Machinery Directive, specifying the solutions adopted. The risk assessment is one of the documents included in the automation system's technical file. This must be compiled by a professional installer.

Considering the risk situations that may arise during installation phases and use of the product, the automation system must be installed in compliance with the following safety precautions:

never make modifications to any part of the automation system other than those specified in this manual. Operations of this type can only lead to malfunctions. The manufacturer declines all liability for damage caused by unauthorised modifications to products;

if the power cable is damaged, it must be replaced by the manufacturer or its after-sales service, or in all cases by a person with similar qualifications, to prevent all risks;

do not allow parts of the automation system to be immersed in water or other liquids. During installation ensure that no liquids are able to enter the various devices; should this occur, disconnect the power supply immediately and contact a Key Automation Service Centre. Use of the automation system in these conditions may cause hazards;

never place automation system components near to sources of heat or expose them to naked lights. This may damage system components and cause malfunctions, fire or hazards;

ATTENTION !

The drive shall be disconnected from its power source during cleaning, maintenance and when replacing parts. If the disconnect device is not in a visible location, affix a notice stating: "MAINTENANCE IN PROGRESS":

connect all devices to an electric power line equipped with an earthing system;

the product cannot be considered to provide effective protection against intrusion. If effective protection is required, the automation system must be combined with other devices;

the product may not be used until the automation system "commissioning" procedure has been performed as specified in the "Automation system testing and commissioning" section;

the system power supply line must include a circuit breaker device with a contact gap allowing complete disconnection in the conditions specified by class III overvoltage;

use unions with IP55 or higher protection when connecting hoses, pipes or cable glands;

the electrical system upstream of the automation system must comply with the relevant regulations and be constructed to good workmanship standards;

this appliance can be used by children aged from 8 years and above and persons with reduced physical, sensory or mental capabilities or lack of experience and knowledge if they have been given supervision or instruction concerning use of the appliance in a safe way and understand the hazards involved;

before starting the automation system, ensure that there is no-one in the immediate vicinity;

before proceeding with any cleaning or maintenance work on the automation system, disconnect it from the electrical mains;

special care must be taken to avoid crushing between the part operated by the automation system and any fixed parts around it;

children must be supervised to ensure that they do not play with the equipment;

drive is not to be used with doors having openings exceeding 50mm in diameter or having edges or protruding parts a person could grip or stand on;

that the drive cannot be used with a driven part incorporating a wicket door unless the drive can only be operated with the wicket door in the safe position;

in the case of detection of an obstacle during its closing travel, the garage door reverses its travel direction, releasing the obstacle until it opens completely;

install the actuating member for the manual release at a height less than 1,8m. If removable,

the actuating member should be stored in direct vicinity of the door;

install any fixed control at a height of at least 1,5m and within sight of the door but away from moving parts;

after installation, ensure that the mechanism is properly adjusted and that the drive reverses or the object can be freed when the door contacts a 50mm high object placed on the floor (for drives incorporating an entrapment protection system depending on contact with the bottom edge of the door);

after installation, ensure that parts of the door do not extend over public footpaths or roads;

when the appliance is provided with a separate stop button, that stop button shall be unambiguously identifiable.

ATTENTION !

Frequently examine the installation for imbalance where applicable and signs of wear or damage to cables, springs and mounting. Do not use if repair or adjustment is necessary.

ATTENTION !

Packaging components (cardboard, plastic, etc.), duly separated, must be placed in the appropriate bins. Device components such as electronic boards, metal parts, batteries, etc. must be separated and differentiated. For the methods of disposal, the rules in force in the place of installation must be applied. DO NOT DISPOSE IN THE ENVIRONMENT!



KEY AUTOMATION reserves the right to amend these instructions if necessary; they and/or any more recent versions are available at www.keyautomation.com

2 - PRODUCT OVERVIEW

2.1 - Description of the product

The UNDER gear motors are destined to be installed in systems for the automation of gates with hinged doors.

The UNDER gear motors have been designed and constructed to be fitted onto hinged doors within the weight limits indicated in the

technical specifications table.

The use of gear motors for applications which differ from those indicated above is prohibited.

2.2 - Model and technical characteristics

Code	Description
UND	For swing gates with maximum length 3,5 m, 230 Vac motor, with opening and closing mechanical stops. Cable length 1.5 m
UND10	For swing gates with maximum length 3,5 m, 230 Vac motor, with opening and closing mechanical stops. Cable length 10 m
UND24	For swing gates with maximum length 3,5 m, 24 Vdc motor, without encoder, with opening and closing mechanical stops
UND24E	For swing gates with maximum length 3,5 m, 24 Vdc motor, with encoder, with opening and closing mechanical stops
UND24F	For pedestrian entrances with swing gates with a maximum length of 3 m, 24 Vdc motor, with encoder and with opening and closing limit switches

TECHNICAL DATA

MODELS		UND	UND10	UND24	UND24E	UND24F
TECHNICAL SPECIFICATIONS						
Torque	Nm	300	300	250	250	130
Working cycle	%	30	30	80	80	50
Opening time at 90°	sec	20	20	18-25	18-25	10-15
Control board		CT202	CT202	14AB2	14AB2	14AB2F
Power supply	Vac (Vdc)	230	230	(24)	(24)	(24)
Absorption	A	1	1	5	5	5
Engine power	W	230	230	120	120	120
Capacitor	µF	10	10	-	-	-
Thermoprotection	°C	150	150	-	-	-
Degree of protection	IP	67	67	67	67	67
Dimensions (L - P - H)	mm	345 - 185 - 125	345 - 185 - 125	345 - 185 - 125	345 - 185 - 125	345 - 185 - 125
Weight	Kg	11	11	10,8	10,8	10,8
Operating temperature	°C	-20° +55°	-20° +55°	-20° +55°	-20° +55°	-20 + 55
Leaves maximum weight	Kg	600	600	600	600	300

3 - PRELIMINARY CHECKS

Before installing this product, verify and check the following steps:

- Check that the gate or door are suitable for automation
- The weight and size of the gate or door must be within the maximum permissible operating limits specified in Fig. 2
- Check the presence and strength of the security mechanical stops of the gate or door
- Check that the mounting area of the product is not subject to flooding
- Conditions of high acidity or salinity or proximity to heat sources could cause malfunction of the product
- Extreme weather conditions (for example the presence of snow, ice, high temperature range, high temperatures) may increase the friction and therefore the force required for the handling and initial starting point may be higher than under normal conditions.
- Check that the manual operation of gate or door is smooth and friction-free and there is no risk of derailment of the same
- Check that the gate or door are in equilibrium and stationary if left in any position
- Check that the power line to supply the product is equipped with proper grounding safety and protected by a magnetothermal and differential security device
- Provide the power system with a disconnecting device with a gap of contacts enabling full disconnection under the conditions dictated by the overvoltage category III.
- Ensure that all materials used for the installation comply with current regulations

4 - PRODUCT INSTALLATION

4.1 - Installation

⚠ ATTENTION !

They shall state that the installer shall check that the temperature range marked on the drive is suitable for the location.

Before starting the installation, make sure that the product is intact and that the packaging contains all the components shown. Make sure that the mounting area is compatible with the overall dimensions (Fig.1).

Check the allowed use limitation in the diagram in Fig.2

Fig.3 is an example of a typical system:

- Operators (1)
- Photocells (2)
- Posts for photocells (3)
- Flashing light with integrated aerial (4)
- Key or digital switch (5)

Positioning the foundation box and the lever control and blocking system

Depending on the dimensions, dig a suitably sized foundation ditch (it is recommended to provide adequate drainage in order to avoid water pooling).

Place the foundation box inside the trench, with the support pivot aligned with the hinge axis.

Install a conduit for the electrical cables, and another for drainage. Embed the foundation box in concrete, ensuring it is level and plumb (Fig.4)

⚠ ATTENTION !

Ensure that the concrete used is properly cured prior to proceeding with the following steps.

Insert the ball E into the special hole after having greased it.

Insert the control rod A over the foundation box supporting pivot B. Fix with a strong welding the wing of the gate on the release lever C, then put everything on the driving bracket A. Grease the mechanism using the appropriate grease nipple D (Fig.4a).

Installing the gear motor

Place the motor reducer gear unit inside the foundation box. Fix the motor reducer in place inside the foundation box by tightening the 4 nuts (Fig.5).

Assemble the lever engine (1) on the motor shaft and tighten the screw (2).

Connect the lever engine (1) command to the bracket (3) through the lever (4) (Fig.5a).

Connect the motor to the control panel following the instructions in the manual installation of the card.

Installation of the limit switches in closing

Move the gate in a position fully closed, then adjust and fasten the screw (Fig. 6).

Installation of the limit switches in opening

Place the gate in the maximum open position, and then then adjust and fasten the screw (Fig. 6a).

⚠ ATTENTION !

Your gate shall be equipped with central and side stops, which are fundamental for the good system operation. (Fig 7).

⚠ ATTENTION !

The automation system must be equipped with a pressure-sensitive edge protecting all possible crushing points (hands, feet, etc.) in accordance with the requirements of the EN 13241-1 standard.

4.2 - Electrical connections

UNDER 230V (UND/UND10)

COLOR CABLE	RIGHT	LEFT
Black	Opening	Closing
Gray	Common	Common
Brown	Closing	Opening
Yellow/Green	GND	GND

⚠ ATTENZIONE !

To operate the engine 230V is essential to connect the capacitor between black and brown of the motor.

UNDER 24V	UND24		UND24F/UND24E	
COLOR CABLE	RIGHT	LEFT	RIGHT	LEFT
Blue	Opening	Closing	Opening	Closing
Brown	Closing	Opening	Closing	Opening
Black	-	-	+ Encoder	
Yellow/Green	-	-	S Encoder	
Gray	-	-	- Encoder	

⚠ ATTENTION !

Always connect the earth cable to the mains power earth system with a cable minimum cross sectional area of 1.5 mm²

4.3 - Emergency unblocking

In the case of a power failure, the gate can be unblocked mechanically by operating the motor.

Insert the supplied unlocking key and rotate completely the handle (above 90°) (Fig. 8).

To lock back follow the reverse procedure.

5- TESTING AND COMMISSIONING THE AUTOMATION

The testing of the system must be performed by qualified technicians who must perform the tests required by relevant legislation related to risks, ensuring compliance with the provisions of the regulations, in

particular the EN12453 standard, which specifies the testing methods for the automation of doors and gates.

5.1 Testing

All system components must be tested following the procedures outlined in the respective instruction manuals.

Check that they meet the guidelines in Chapter 1 - Safety warnings
Check that the gate or door can move freely once the automation is unlocked, and that they are in equilibrium and stationary if left in any position.

Check the correct operation of all connected devices (photocells, sensitive edges, emergency buttons, etc.), testing the opening, closing and stopping of the gate or door via the connected control devices (transmitters, buttons, switches).

Carry out measurements of the impact force, as prescribed by standard EN12453 adjusting the functions of speed, motor force and deceleration of the unit if the measurements do not give the desired results until you find the right setting.

5.2 Commissioning

Following the successful testing of all (and not just some) devices in the system you can proceed with the commissioning.

You must prepare, and keep for 10 years, the technical file of the system with the wiring diagram, drawing or photo of the system, risks analysis and solutions adopted, manufacturer declaration of conformity of all devices connected, instruction manual of each device and maintenance schedule of the system.

Fix on the gate or door a plaque indicating the automation data, the name of the person responsible for the commissioning, the serial number and year of construction, the CE mark.

Attach a plaque indicating the steps required to manually unlock the system.

Implement and deliver to the end user the declaration of conformity, the instructions and warnings for use for the end user and the maintenance schedule of the system.

Make sure the user understands proper automatic, manual and emergency operation of the automation.

Inform the end user in writing of the dangers and risks still present.

6 - IMAGES

Fig. 1 IT - Dimensioni d'ingombro

EN - Space dimensions
FR - Dimensions d'encombrement
ES - Dimensiones

DE - Abmessungen

PT - Dimensões globais
PL - Wymiary

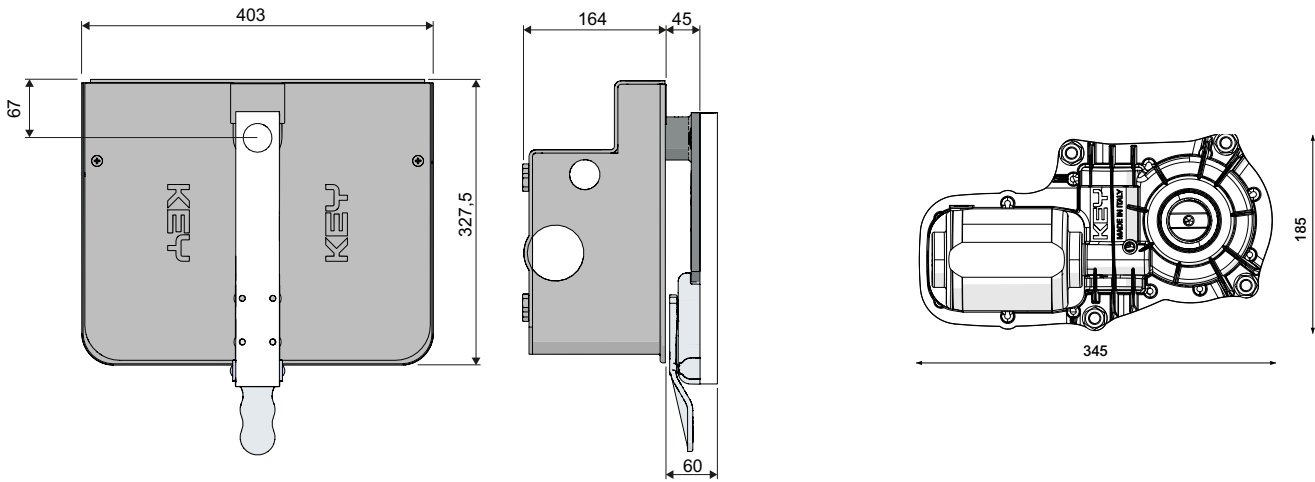
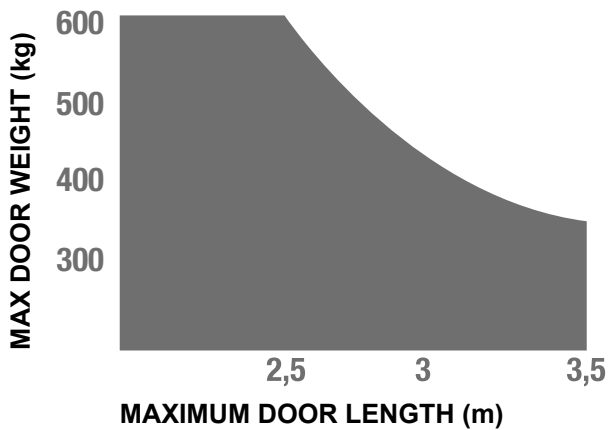

Fig. 2 IT - Limiti di impiego

EN - Use limitations
FR - Limites d'utilisation
ES - Límites de uso

DE - Einsatzgrenzen

PT - Limites de uso
PL - Ograniczenia użytkowania



KG

IT - Peso massimo dell' anta del cancello

EN - Maximum weight of the gate door

FR - Poids maximum du battant du portail

ES - Peso máximo de la puerta de la cancela

DE - Maximales Gewicht des Torflügels

PT - Peso máximo do painel do portão

PL - Waga maksymalna skrzydła bramy

m

IT - Lunghezza massima dell' anta del cancello

EN - Maximum length of the gate door

FR - Longueur maximum du battant du portail

ES - Longitud máxima de la puerta de la cancela

DE - Maximale Länge des Torflügels

PT - Comprimento máximo do painel do portão

PL - Długość maksymalna skrzydła bramy

Fig. 3 IT - Installazione tipica

EN - Typical Installation
FR - Installation type
ES - Instalación típica

DE - Typische Installation

PT - Gráfico ângulo de abertura

PL - Wykres kąta otwarcia



Fig. 4 IT - Posizionamento della cassa
EN - Positioning the foundation box
FR - Positionnement de la caisse de fondation
ES - Ubicación de la caja de cimentación

DE - Positionierung des fundamentkastens
PT - Posicionamento da caixa de fundação
PL - Ustawianie podstawy i dźwigni

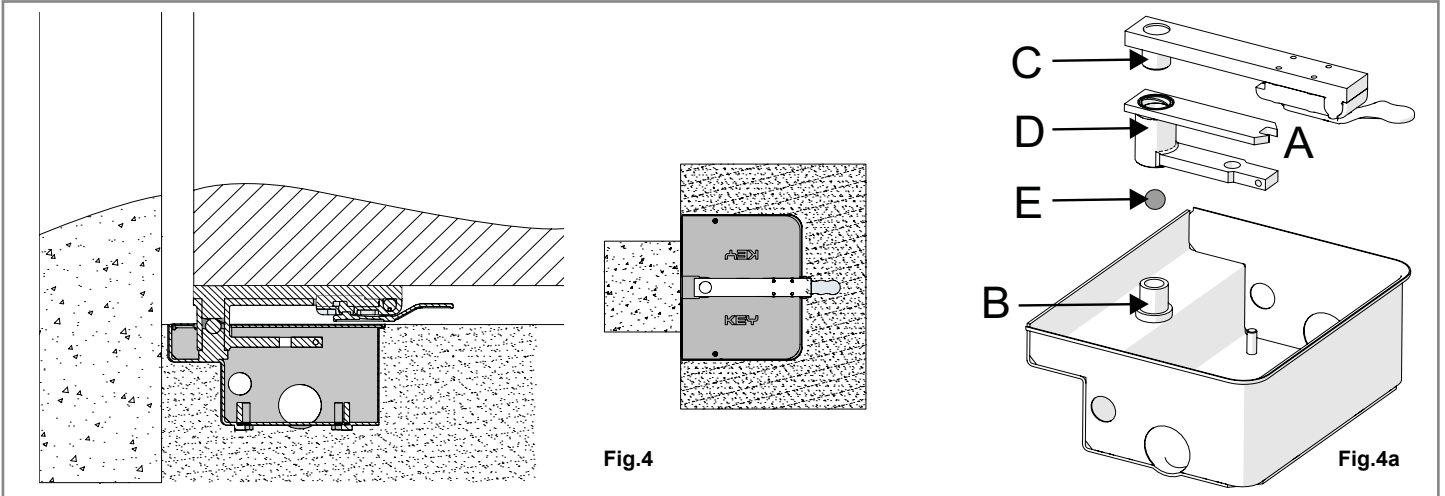

Fig. 5 IT - Installazione del motoriduttore
EN - Installing the motor reducer
FR - Mise en place du motoréducteur
ES - Instalación del motorreductor

DE - Installation des getriebemotors
PT - Instalação do motorreductor
PL - Instalowanie motorreduktora

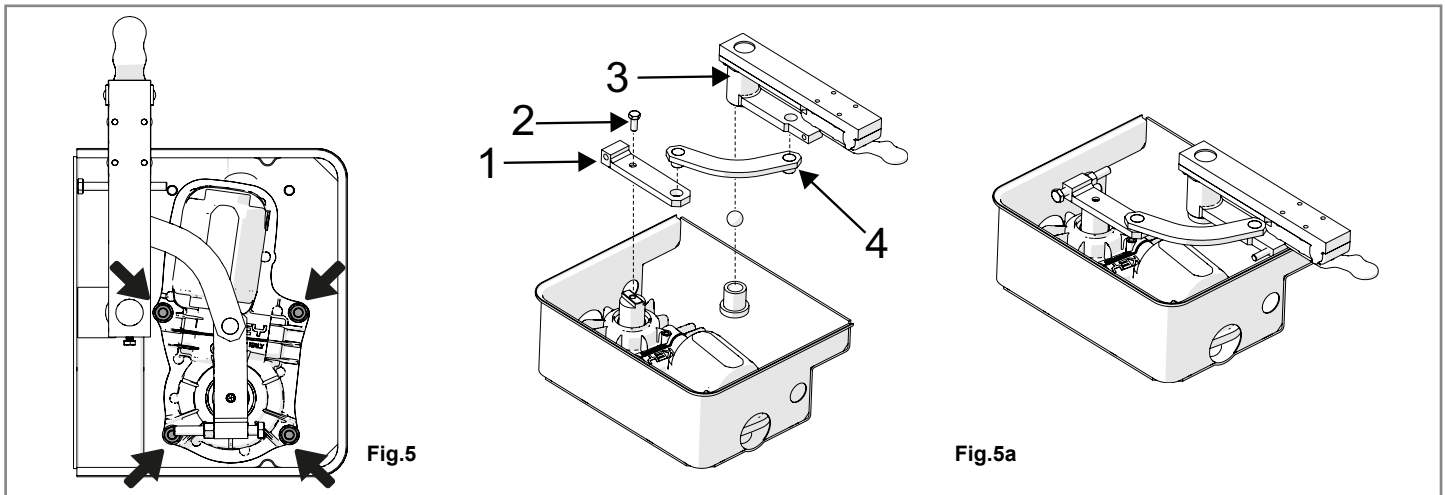

Fig. 6 IT - Installazione del fermi finecorsa
EN - Installation of the limit switches
FR - Installation des baguettes de blocage
ES - Instalación de los topos de detención

DE - Einbau der verschlusschalter
PT - Instalação dos travões de fim de curso
PL - Instalacja włączników ogranicznika

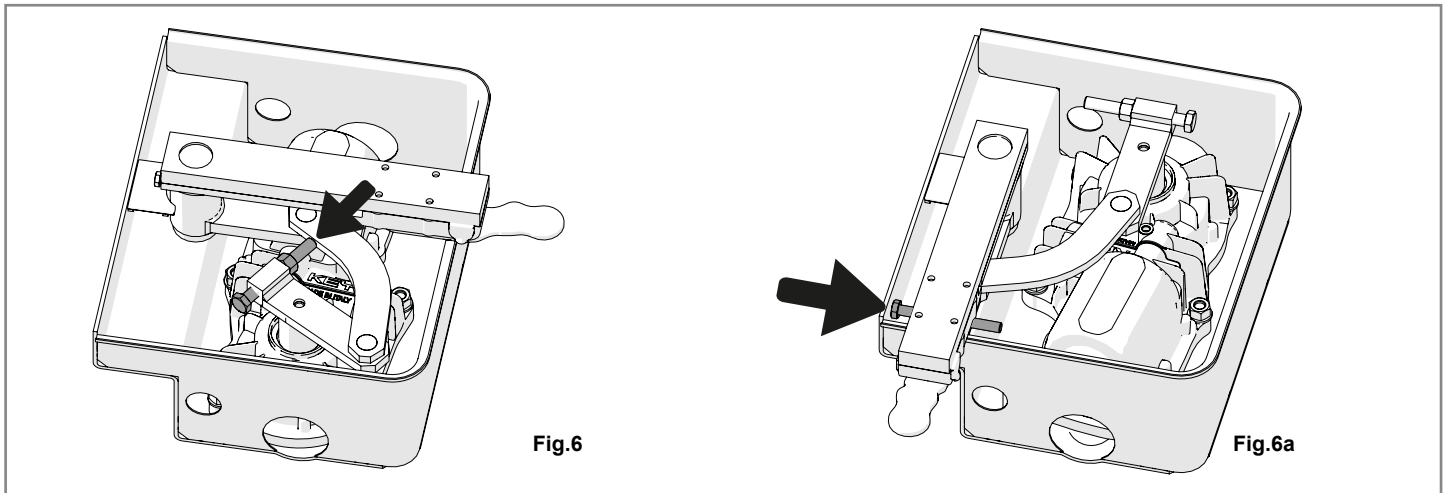

Fig. 7 IT - Installazione del fermi finecorsa
EN - Installation of the limit switches
FR - Installation des baguettes de blocage
ES - Instalación de los topes de detención

DE - Einbau der verschlusschalter
PT - Instalação dos travões de fim de curso
PL - Instalacja włączników ogranicznika

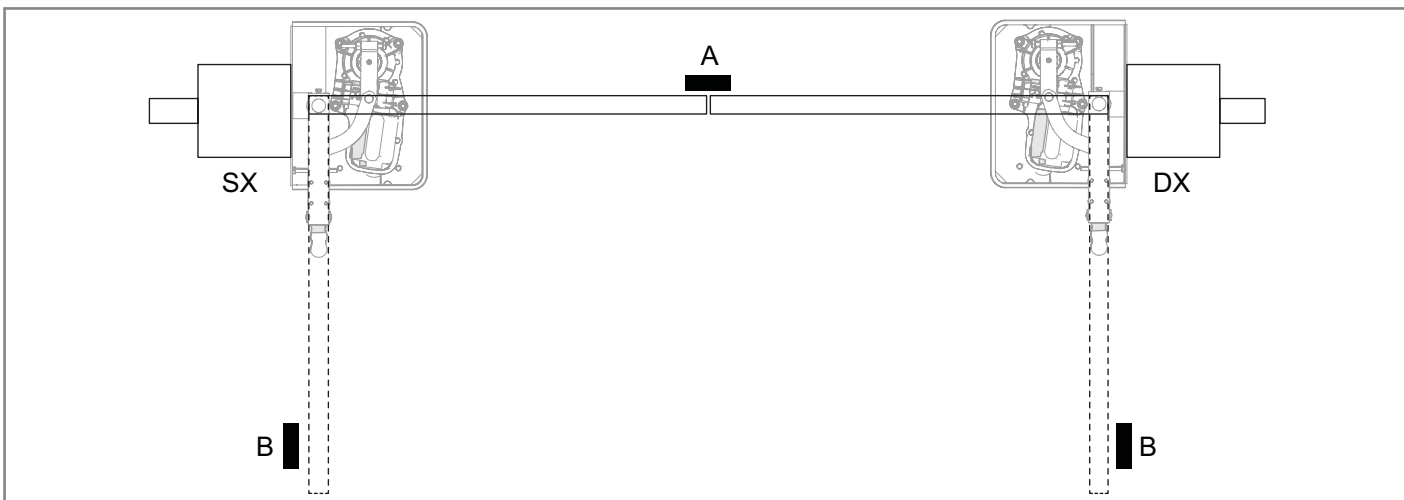
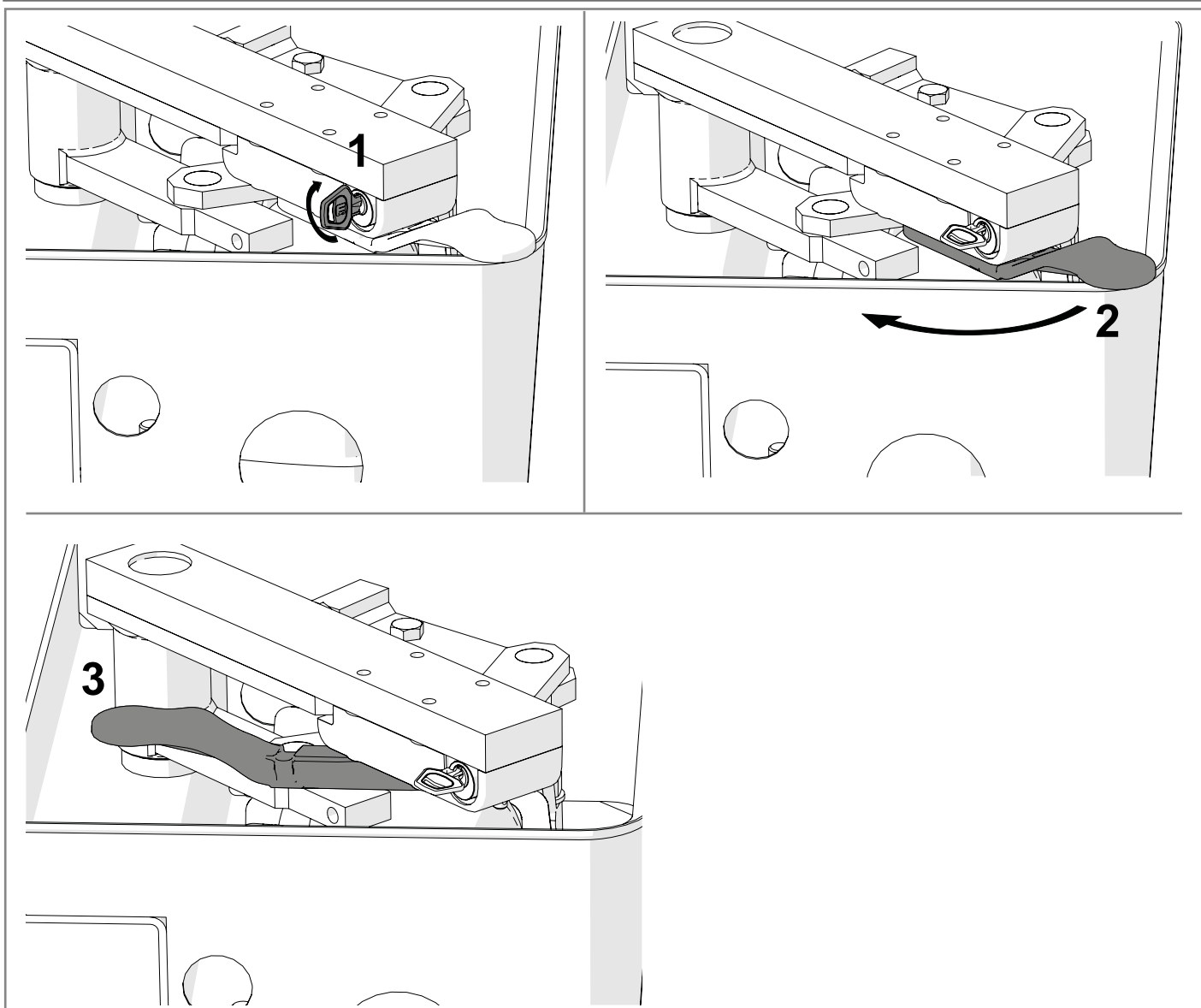

Fig. 8 IT - Sblocco di emergenza
EN - Emergency unblocking
FR - Déverrouillage d'urgence
ES - Desbloqueo de emergencia

DE - Notfallfreigabe
PT - Desbloqueio de emergência
PL - Odblokowanie awaryjne



DICHIARAZIONE DI INCORPORAZIONE DI QUASI MACCHINA DECLARATION OF INCORPORATION OF PARTLY COMPLETED MACHINERY

Il sottoscritto Nicola Michelin, Amministratore Delegato dell'azienda
The undersigned Nicola Michelin, General Manager of the company

Key Automation s.r.l., via Meucci 23, 30027 San Donà di Piave (VE) – ITALIA

dichiara che il prodotto tipo:
declares that the product type:

UND

Motoriduttore elettromeccanico interrato per cancelli a battente fino a 3,5m, 24Vdc e 230Vac
Electromechanical underground gear motor for swing gates, leaves up to 3,5m, 24Vdc and 230Vac

Models:
Models:

UND, UND10, UND24, UND24E, UND24F

E' conforme a quanto previsto dalle seguenti direttive comunitarie:
Complies with the following community (EC) regulations:

Direttiva macchine / *Machinery Directive 2006/42/EC*
Direttiva compatibilità elettromagnetica / *EMC Directive 2014/30/EU*
Direttiva bassa tensione / *Low voltage Directive 2014/35/EU*
Direttiva RoHS / *RoHS Directive 2011/65/EU*

Secondo quanto previsto dalle seguenti norme armonizzate:
In accordance with the following harmonized standards regulations:

EN IEC 55014-1:2021, EN IEC 55014-2:2021
EN 60335-1:2012+A15:2021, EN 60335-2-103:2015
EN IEC 61000-3-2:2019, IEC 61000-3-3:2013 + A2:2021
EN IEC 61000-6-1:2019, EN IEC 61000-6-3:2021
EN 62233:2008

Dichiara che la documentazione tecnica pertinente al prodotto è stata redatta conformemente a quanto previsto dalla direttiva 2006/42/CE Allegato VII parte B e verrà fornita a fronte di una richiesta adeguatamente motivata dalle autorità nazionali.
Declares that the technical documentation is compiled in accordance with the directive 2006/42/EC Annex VII part B and will be transmitted in response to a reasoned request by the national authorities.

Dichiara altresì che non è consentita la messa in servizio del prodotto finché la macchina, in cui il prodotto è incorporato, non sia stata dichiarata conforme alla direttiva 2006/42/CE.
He also declares that is not allowed to use the above mentioned product until the machine, in which this product is incorporated, has been identified and declared in conformity with the regulation 2006/42/EC.

San Donà di Piave (VE), 29/03/23

Amministratore Delegato
General Manager
Nicola Michelin



Key Automation S.r.l.
Via Meucci 23
30027 San Donà di Piave (VE)
P.IVA 03627650264 C.F. 03627650264
info@keyautomation.it

Capitale sociale 154.000 € i.v.
Reg. Imprese di Venezia 03627650264
REA VE 326953
<http://www.keyautomation.com/>



Certificazione con sistema di gestione certificato

Key Automation S.r.l.

Via Meucci 23 - 30027 San Donà di Piave (VE)

T. +39 0421 307456

info@keyautomation.it - www.keyautomation.com

Instruction version

580UND REV04