

ALT3KF ALT4K ALT6K

Automazione per barriere stradali con asta da 3 a 8 m
Automation for road barriers with 3 to 8 m bars
Automatisme pour barrières routières à lisse de 3 à 8 m
Automatización para barreras viales con mástil desde 3 hasta 8 m
Antrieb für Schrankenanlagen mit Baumlänge von 3 bis 8 m
Automatismo para barreiras de trânsito com haste de 3 a 8 m
Automatyka do szlabanów drogowych z ramieniem od 3 do 8 m



TABLE OF CONTENTS

1	Safety warnings	pag. 31
2	Product Introduction	pag. 32
2.1	Technical characteristics	pag. 32
3	Preliminary Checks	pag. 33
4	List of cables required	pag. 33
5	Product installation	pag. 34
5.1	Installation	pag. 34
5.2	Reversal of opening direction	pag. 34
5.3	Bar release	pag. 35
5.4	Bar angle adjustment	pag. 35
5.5	Barrier configuration with accessories	pag. 35
5.6	ALT324KF Accessories and bar weight balancing	pag. 35
5.7	ALT424K Accessories and bar weight balancing	pag. 36
5.8	ALT624K Accessories and bar weight balancing	pag. 37
5.9	ALT624K with ASTL8 Accessories and bar weight balancing	pag. 38
5.10	Balancing	pag. 38
6	Control Unit	pag. 39
6.1	Description of the control unit	pag. 39
6.2	Description of the connections	pag. 39
6.3	Models and technical characteristics	pag. 39
6.4	Electrical connections	pag. 40
6.5	Display during normal operation	pag. 41
6.6	Autolearning of the travel stroke	pag. 43
6.7	Learning a transmitter	pag. 43
6.8	Customising the system - BASIC MENU	pag. 44
7	Further Details - Advanced Menu	pag. 47
8	Testing and commissioning	pag. 51
8.1	Testing	pag. 51
8.2	Commissioning	pag. 51
9	Maintenance	pag. 52
9.1	Maintenance schedule	pag. 52
9.2	Replacements schedule	pag. 53
10	Instructions and warnings for the end user	pag. 55
10.1	Maintenance History Log	pag. 56
11	Images	pag. 198
12	EC declaration of conformity	pag. 207

1 - SAFETY WARNINGS

⚠ ATTENTION !

ORIGINAL INSTRUCTIONS - important safety instructions. Follow the instructions since incorrect installation can lead to severe injury! Save these instructions.

Read the instructions carefully before proceeding with installation.

The design and manufacture of the devices making up the product and the information in this manual are compliant with current safety standards. However, incorrect installation or programming may cause serious injury to those working on or using the system. Compliance with the instructions provided here when installing the product is therefore extremely important.

If in any doubt regarding installation, do not proceed and contact the Key Automation Technical Service for clarifications.

According to European standards, the construction of a motorized barrier must comply with the provisions of Directive 2006/42/EC (Machinery Directive) including the standards EN 12453 and EN 13241-1, which ensure the conformity of the automation.

Therefore, final connection of the automation system to the electrical mains, system testing, commissioning and routine maintenance must be performed by skilled, qualified personnel, in observance of the instructions in the "Testing and commissioning the automation system" section.

The aforesaid personnel are also responsible for the tests required to verify the solutions adopted according to the risks present, and for ensuring observance of all legal provisions, standards and regulations, with particular reference to all requirements of the EN 12453 standard which establishes the test methods for testing barrier automation systems.

⚠ ATTENTION !

Before starting installation, perform the following checks and assessments:

ensure that every device used to set up the automation system is suited to the intended system overall. For this purpose, pay special attention to the data provided in the "Technical specifications" section. Do not proceed with installation if any one of these devices is not suitable for its intended purpose;

check that the devices purchased are sufficient to guarantee system safety and functionality;

perform a risk assessment, including a list of the essential safety requirements as envisaged in Annex VII of the Machinery Directive, specifying the solutions adopted. The risk assessment is one of the documents included in the automation system's technical file. This must be compiled by a professional installer.

Considering the risk situations that may arise during installation phases and use of the product, the automation system must be installed in compliance with the following safety precautions:

never make modifications to any part of the automation system other than those specified in this manual. Operations of this type can only lead to malfunctions. The manufacturer declines all liability for damage caused by unauthorised modifications to products;

if the power cable is damaged, it must be replaced by the manufacturer or its after-sales service, or in all cases by a person with similar qualifications, to prevent all risks;

do not allow parts of the automation system to be immersed in water or other liquids. During installation ensure that no liquids are able to enter the various devices;

should this occur, disconnect the power supply immediately and contact a Key Automation Service Centre. Use of the automation system in these conditions may cause hazards;

never place automation system components near to sources of heat or expose them to naked lights. This may damage system components and cause malfunctions, fire or hazards;

⚠ ATTENTION !

The drive shall be disconnected from its power source during cleaning, maintenance and when replacing parts. If the disconnect device is not in a visible location, affix a notice stating: "MAINTENANCE IN PROGRESS":

connect all devices to an electric power line equipped with an earthing system;

the product cannot be considered to provide effective protection against intrusion. If effective protec-

tion is required, the automation system must be combined with other devices;

the product may not be used until the automation system “commissioning” procedure has been performed as specified in the “Automation system testing and commissioning” section;

the system power supply line must include a circuit breaker device with a contact gap allowing complete disconnection in the conditions specified by class III overvoltage;

use unions with IP55 or higher protection when connecting hoses, pipes or cable glands;

the electrical system upstream of the automation system must comply with the relevant regulations and be constructed to good workmanship standards;

this appliance can be used by children aged from 8 years and above and persons with reduced physical, sensory or mental capabilities or lack of experience and knowledge if they have been given supervision or instruction concerning use of the appliance in a safe way and understand the hazards involved;

before starting the automation system, ensure that there is no-one in the immediate vicinity;

before proceeding with any cleaning or maintenance work on the automation system, disconnect it from the electrical mains;

special care must be taken to avoid crushing between the part operated by the automation system and any fixed parts around it; children must be supervised to ensure that they do not play with the equipment.

⚠ ATTENTION !

Frequently examine the installation for imbalance where applicable and signs of wear or damage to cables, springs and mounting. Do not use if repair or adjustment is necessary.

⚠ ATTENTION !

Since the automation system exceeds 10 kg in weight, it must be handled using a truck (IEC 60335-2-103:2015)

⚠ ATTENTION !

Packaging components (cardboard, plastic, etc.), duly separated, must be placed in the appropriate bins. Device components such as electronic boards, metal parts, batteries, etc. must be separated and differentiated. For the methods of disposal, the rules in force in the place of installation must be applied. DO NOT DISPOSE IN THE ENVIRONMENT!



KEY AUTOMATION reserves the right to amend these instructions if necessary; they and/or any more recent versions are available at www.keyautomation.com

2 - INTRODUCING THE PRODUCT

2.1 - Technical characteristics

DATI TECNICI	900ALT324KF	900ALT324LFK	900ALT424K	900ALT424LK	900ALT624K	900ALT624LK
Torque	40 Nm		200 Nm		305 Nm	
Working cycle (cycles/hour)	600		400		120	
Opening time 90°	1 sec		3,5 sec		6 sec / 12 sec*	
Control unit	CT10224F		CT10224		CT10224	
Max. number of transmitters storage FIX CODE	150 transmitters					
Max. number of transmitters storage ROLLING CODE	150 transmitters					
Power supply	230 V ±10% 50-60Hz	120 V ±10% 50-60Hz	230 V ±10% 50-60Hz	120 V ±10% 50-60Hz	230 V ±10% 50-60Hz	120 V ±10% 50-60Hz
230 Vac power supply line fuses	1.6 A slow-acting					
Standby power	10 W ⁽¹⁾		10 W ⁽¹⁾		10 W ⁽¹⁾	
Rated power	30 W		40 W		40 W	
Maximum input power	60 W		90 W		100 W	
Red and green light integrated	yes		yes		yes	
Red and green light bar	no		yes		yes	
Sound pressure	< 70 dB(A)		< 70 dB(A)		< 70 dB(A)	
Protection class	IP 54		IP 54		IP 54	

Use in a particularly acid / saline / explosive atmosphere	No	No	No
Dimensions (L-P-H)	400-280-1188 mm	320-220-1110 mm	400-280-1188 mm
Weight	62 Kg	47 Kg	67 Kg
Operating temperature	-20°C + 55°C	-20°C + 55°C	-20°C + 55°C
Maximum length of rod	3 m	4 m	6 (8 mt)

* with 8 m bar

(1) with two fixed red led discs

3 - PRELIMINARY CHECKS

Before installing the product, perform the following checks and inspections:

- make sure that the product fixing zone is not subject to flooding;
 - check that the electricity supply line to which the product is to be connected is suitably earthed and protected by an overload and differential safety breaker device;
 - the system power supply line must include a circuit breaker device with a contact gap allowing complete disconnection in the conditions specified by class III overvoltage;
 - ensure that all the material used for installation complies with the relevant regulatory standards;
 - Please refer to Fig. 1 and in particular to the table with the nomenclature of the main parts to which reference will be made throughout this manual.
 - Please refer to Figs. 2 and 3 showing the overall dimensions and the typical installation diagram of an automation system for road barrier.
- Before powering and starting up the product, check and verify the

following points:

- check that the manual movement of the barrier is smooth and free from higher friction areas and jamming;
- check that the barrier bar, moved manually, is still balanced if inclined to an angle of 45°..

Warnings:

- high acidity or salinity or nearby heat sources might cause the product to malfunction;
- in case of extreme weather conditions (e.g. snow, ice, wide temperature variations or high temperatures), friction may increase, causing a corresponding rise in the force needed to operate the system;

4 - LIST OF CABLES REQUIRED

The cables required for connection of the various devices in a standard system are listed in the cables list table. The cables used must be suitable for the type of installation; for

example, an H03VV-F type cable is recommended for indoor applications, while H07RN-F is suitable for outdoor applications.

ELECTRIC CABLE TECHNICAL SPECIFICATIONS:

Connection	cable	maximum allowable limit
Control unit power supply line	1 x cable 3 x 1,5 mm ²	20 m *
Antenna	1 x cable type RG58	20 m (advised < 5 m)
Transmitter photocells	1 x cable 2 x 0,5 mm ²	20 m
Receiver photocells	1 x cable 4 x 0,5 mm ²	20 m
Sensitive edge	1 x cable 2 x 0,5 mm ²	20 m
Key-switch	1 x cable 4 x 0,5 mm ² **	20 m

* If the power supply cable is more than 20 m long, it must be of larger gauge (3x2.5mm²) and a safety grounding system must be installed near the automation unit.

5 - PRODUCT INSTALLATION

5.1 - Installation

⚠ ATTENTION !

The installer must ensure that the temperature range shown on the automation device is suitable for its required installation position.

Before proceeding with the installation, check the integrity of the product and ensure that all the components are in the package.

1. Provide a foundation of adequate dimensions for the fixing plate of the barrier to be installed (Fig. 4) and prepare one or more tubes for the routing of electric cables (Fig. 5a).

2. Assemble the anchoring clamps on the anchor plate and fix them using the 4 bolts supplied.

3. Cast concrete in the foundation trench and position the foundation plate.

⚠ ATTENTION !

Check that the plate is perfectly level and parallel to the opening.

4. Wait for the concrete to set completely.

5. Unscrew the 4 nuts that keep the base fixed to the clamps and position the cabinet on the plate (Fig. 5b).

⚠ ATTENTION !

It is advisable to install the cabinet with the inspection door facing the most easily accessible side.

⚠ ATTENTION !

Never take down the bar for any reason until it is in a horizontal position and never perform an emergency or manual manoeuvre if the bar is not installed.

⚠ ATTENTION !

The barrier must be equipped with mechanical stops for opening and closing that prevent the barrier over-travel.

⚠ ATTENTION !

On ALT624K, before mounting the boom, make sure that the countersunk screw that secures the support plate of the boom is fully tightened (Fig. 14).

5.2 - Reversal of opening direction

The automation systems for ALT road barriers are factory-set for bar mounting facing right - looking at the barrier frontally with respect to the door (Fig. 6a).

If it is necessary to install the bar on the other side, i.e. on the left, like in figure 6b, carry out the operations indicated below

VERSION ALT3KF

- Open the door, loosen the spring tensioning system and then release the springs from the tightening eyelets of the tensioners (Fig. 7 and 8)

- Unscrewing the upper screw, remove the connecting rod between the motor lever and the balancing lever (Fig. 9)

- Remove the two fixing screws of the articulated joint heads of the tensioners (Fig. 10)

- Rotate the balancing lever on the opposite side, all the way to the limit stop (Fig. 11)

- After carrying out this manual manoeuvre (see the procedure for unlocking the bar, Par. 5.3) rotate the motor lever on the opposite side and connect the connecting rod to the balancing lever again (Fig. 12), then restore the transmission drive.

- Screw back in the two fixing screws of the articulated joint heads of the tensioners (Fig. 12) in the positions indicated in Par. 5.6 (ALT324KF Accessories and bar weight balancing) determined according to the length of the bar

- Hook up the springs to the tensioner fixing eyelets and, turning by a few turns, partially restore the tension of the springs (Fig. 13)

- Install the bar in a vertical position and proceed with balancing (next Par. 5.10), (Fig. 14)

VERSION ALT4K

- Open the door, loosen the spring tensioning system and then release the spring from the tightening eyelet of the tensioner (Fig. 7 and 8)

- Remove the fixing screw of the top articulated joint head of the tensioner (Fig. 10)

- After carrying out this manual manoeuvre (see the procedure for unlocking the bar, Par. 5.3) rotate the balancing lever on the opposite side (Fig. 11), all the way to the limit stop, and restore the transmission drive

- Re-tighten the fixing screw of the articulated joint head of the tensioner

(Fig. 12) in the position indicated in Par. 5.7 (ALT424K Accessories and bar weight balancing) determined according to the length of the bar and of the installed accessories

- Hook up the spring to the tensioner fixing eyelet and, turning by a few turns, partially restore the tension of the spring (Fig. 13)

- Install the bar in a vertical position (Fig. 14) and proceed with balancing (following Par. 5.10)

VERSION ALT6K

- Open the door, loosen the spring tensioning system and then release the springs from the tightening eyelets of the tensioners (Fig. 7 and 8)

- Unscrewing the upper screw, remove the connecting rod between the motor lever and the balancing lever (Fig. 9)

- Remove the two fixing screws of the articulated joint heads of the tensioners (Fig. 10)

- Rotate the balancing lever on the opposite side, all the way to the limit stop (Fig. 11)

- After carrying out this manual manoeuvre (see the procedure for unlocking the bar, Par. 5.3) rotate the motor lever on the opposite side and connect the connecting rod to the balancing lever again (Fig. 12), then restore the transmission drive

- Screw back in the two fixing screws of the articulated joint heads of the tensioners (Fig. 12) in the positions indicated in Par. 5.8 (ALT624K Accessories and bar weight balancing) determined according to the length of the bar and of the installed accessories

- Hook up the springs to the tensioner fixing eyelets and, turning by a few turns, partially restore the tension of the springs (Fig. 13)

- Disassemble the rod support plate (Fig. 14) and reassemble it by orienting it upwards. Insert it fully onto the square shaft, possibly with the help of a rubber hammer, lock it firmly in place with the toothed conical washer and fully tighten the countersunk screw

- Install the bar in a vertical position and proceed with balancing (next Par. 5.10), (Fig. 14)

5.3 - Bar release

If it is necessary to manually adjust the barrier bar, proceed as follows (Fig. 15):

- Disconnect the power supply.
- Insert the supplied release key and remove the pad lock, insert the Allen key and rotate it by 90°.
- In this way it is possible to release the internal reducer system to allow for emergency manoeuvring.
- Perform the manual manoeuvre.
- To re-activate the transmission, simply turn the Allen key to return it to its initial position and then close the lock.
- Now you can restore the power supply and check that everything is in good working order.

5.4 - Bar angle adjustment

In the event that the bar limit stops must be adjusted, proceed as follows (Fig. 16):

- Loosen the locknut located on the upper crosspiece of the box
- Adjust the screw to the desired height
- Re-tighten the locking nut again
- Repeat the operation with the other stop

5.5 - Barrier configuration with accessories

Before carrying out, during installation, the first balancing of the bar, the barrier must be configured according to the accessories actually installed.

The following diagrams (Par. 5.6 for ALT324KF, Par. 5.7 for ALT424K, Par. 5.8 for ALT624K) show the optimal fixing positions of the articulated joint heads of the tensioners with respect to the balance lever for your barrier configuration, i.e. by model (ALT324KF, ALT424K or ALT624K), by length of the bar and according to the chosen accessories.

It is therefore necessary to compare these positions with the "factory" ones and if they do not match, loosen the screws that fix the articula-

ted heads of the tensioners to the balance lever and reposition them accordingly:

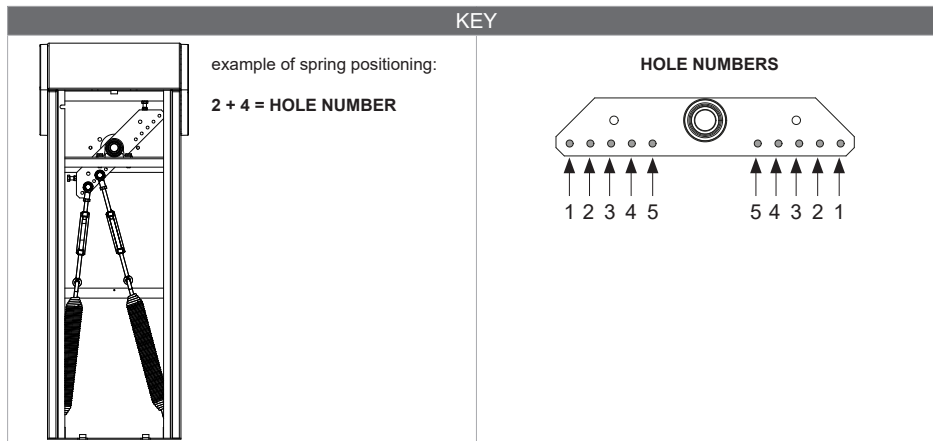

- starting from the "factory" configuration, install the bar in a vertical position. Make sure the bar is locked in this position
- identify, on the basis of the following diagrams, the most suitable position of the articulated joint heads of the tensioners and fix them with the screws to the corresponding holes in the balance lever, tightening the tensioners by a few turns so as to partially increase the springs' tension

5.6 - ALT324KF Accessories and bar weight balancing

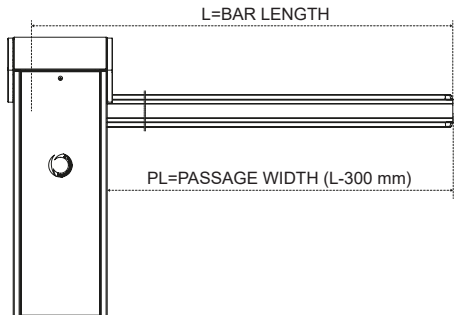

ONLY BAR

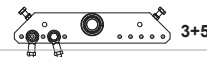

L = BAR LENGTH (mm)	POSITION	SUGGESTED VALUE FOR LS1 PARAMETER	SUGGESTED VALUE FOR LS2 PARAMETER
2400	 3+5	52	55
3000	 1+3	55	68

5.7 - ALT424K Accessories and bar weight balancing

KEY

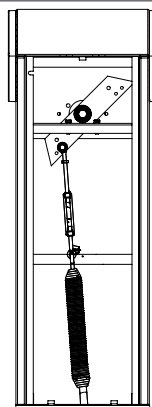

example of spring positioning and type:

2 = HOLE NUMBER

HOLE NUMBERS

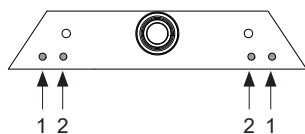

BAR + RUBBER PROFILE

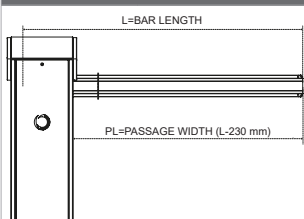

L = BAR LENGTH (mm)	POSITION
3000	2
4000	1

BAR + RUBBER PROFILE + MOBILE SUPPORT

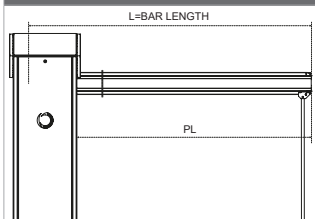

L = BAR LENGTH (mm)	POSITION
3000	2
4000	1

BAR + RUBBER PROFILE + KIT FENCE (1x)

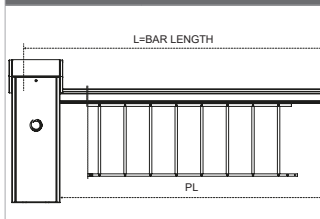

L = BAR LENGTH (mm)	POSITION
3000	2
4000	1

BAR + RUBBER PROFILE + KIT FENCE (2x)

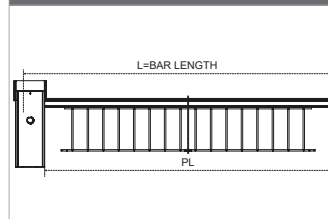

L = BAR LENGTH (mm)	POSITION
3000	-
4000	1

BAR + KIT FENCE (1x) + MOBILE SUPPORT

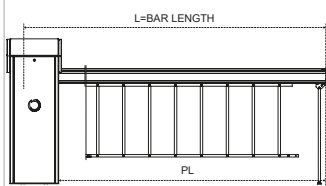

L = BAR LENGTH (mm)	POSITION
3000	2
4000	1

BAR + KIT FENCE (2x) + MOBILE SUPPORT

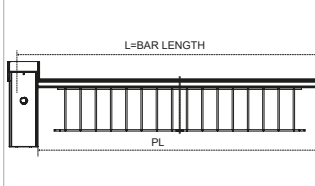

L = BAR LENGTH (mm)	POSITION
3000	-
4000	1

ASTL5 + RUBBER PROFILE

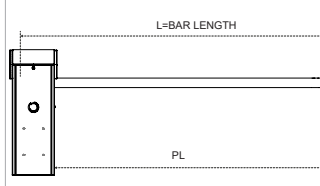

L = BAR LENGTH (mm)	POSITION
5000	1

N.B. The LED strips are always included in the balance system
For ASTL5 it is recommended to combine APFX

5.8 - ALT624K Accessories and bar weight balancing

KEY

<p>example of spring positioning and type:</p> <p>3D1</p> <p>3 = HOLE NUMBER D = SPRING POSITION 1 = SPRING TYPE</p>	<p>HOLE NUMBERS</p>	<p>SPRING POSITION V = vertical position D = diagonal position</p>	<p>SPRING TYPE 1=spring + short tie rod 2=spring + long tie rod</p>
--	----------------------------	---	--

BAR + RUBBER PROFILE	
L = BAR LENGTH (mm)	POSITION
4501-5000	
5001-5500	
5501-6000	

BAR + RUBBER PROFILE + MOBILE SUPPORT	
L = BAR LENGTH (mm)	POSITION
4501-5000	
5001-5500	
5501-6000	

BAR + RUBBER PROFILE + KIT FENCE (1x)	
L = BAR LENGTH (mm)	POSITION
4501-5000	
5001-5500	
5501-6000	

BAR + RUBBER PROFILE + KIT FENCE (2x)	
L = BAR LENGTH (mm)	POSITION
4501-5000	
5001-5500	
5501-6000	

BAR + RUBBER PROFILE + KIT FENCE (3x)	
L = BAR LENGTH (mm)	POSITION
5001-5500	
5501-6000	

BAR + KIT FENCE (1x) + MOBILE SUPPORT	
L = BAR LENGTH (mm)	POSITION
4501-5000	
5001-5500	
5501-6000	

BAR + KIT FENCE (2x) + MOBILE SUPPORT	
L = BAR LENGTH (mm)	POSITION
4501-5000	
5001-5500	
5501-6000	

BAR + KIT FENCE (3x) + MOBILE SUPPORT	
L = BAR LENGTH (mm)	POSITION
5001-5500	
5501-6000	

5.9 - ALT624K with ASTL8 Accessories and bar weight balancing

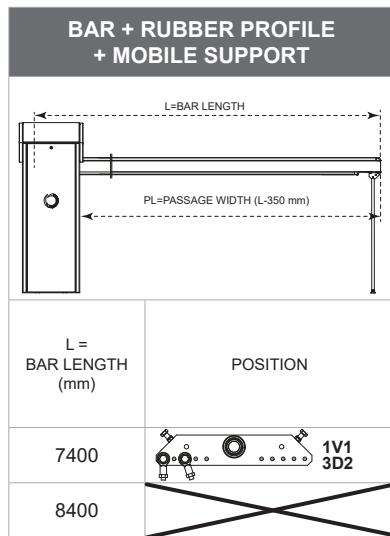
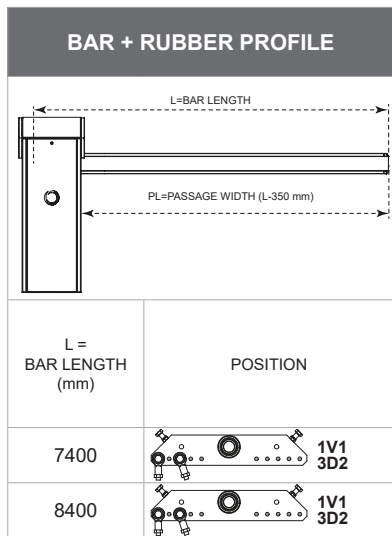
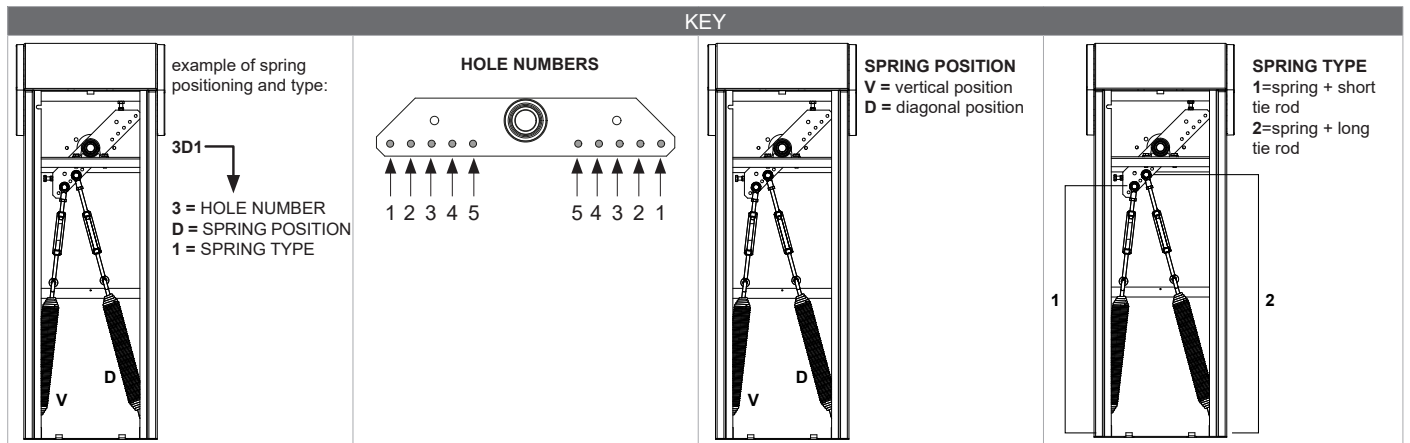

! ATTENTION !

NO KIT FENCE

N.B. The LED strips are always included in the balance system For ASTL8 it is recommended to combine APFX

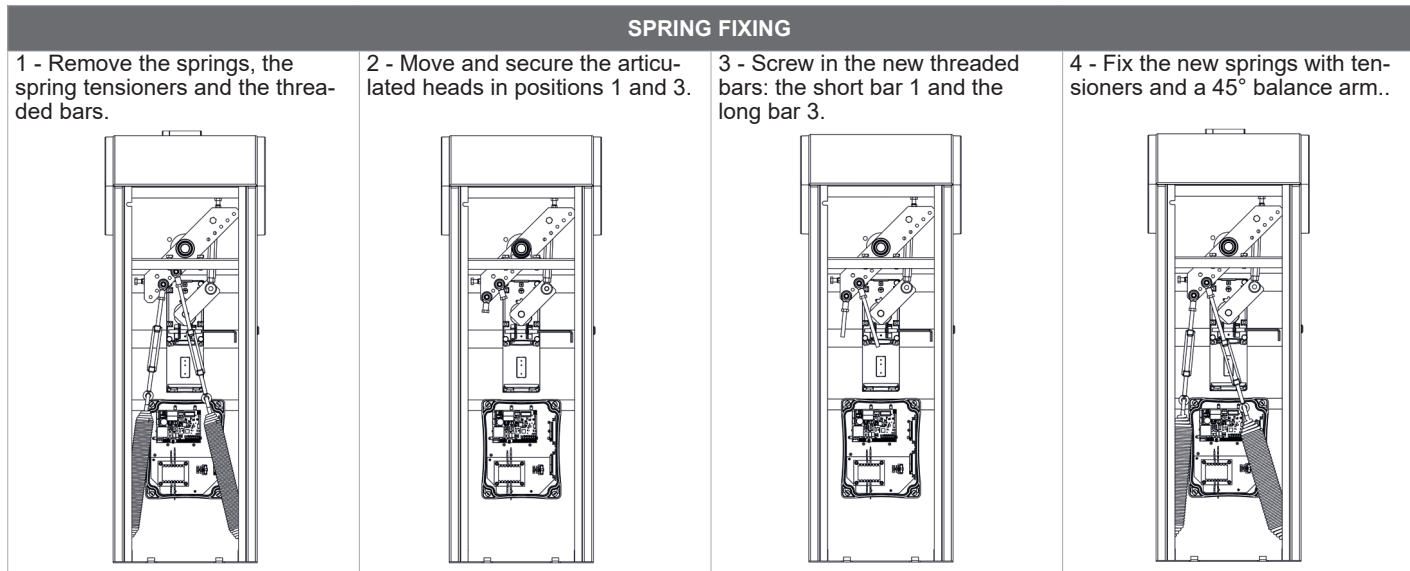

5.10 - Balancing

To balance the bar proceed as follows:

- disconnect the power supply and release the bar as described in paragraph 5.3
- open the barrier door (Fig. 7)
- move the bar manually, keeping its opening angle at approximately 45°
- check that the balancing of the bar opened to an angle of 45° is ensured, i.e. the springs must be able to correctly balance the weight of the bar (Fig. 17)
- if the bar balance is not ensured, bring the bar back to a vertical position and work the tensioners to increase or decrease the tension of the springs until the bar reaches a stable balanced condition at 45°

! ATTENTION !

Stretch the springs progressively so that both can equally contribute to balancing

- tighten the tensioner lock nuts to prevent them from becoming loose during normal operation and lock the bar again
- restore the power supply and check that the automation system is working properly
- **Restore factory setting for 8 mt barrier**

We recommend to check the correct balance every 6 months or every 50,000 opening/closing cycles

6 - CONTROL UNIT

6.1 - Description of the control unit

The CT10224 and CT10224F control units are the most advanced and efficient control systems for Key Automation motors powering the electric opening and closing of electromechanical barriers. Any other improper use of the control unit is prohibited. The CT10224 and the CT10224F control units are equipped with a display that al-

lows for easy programming and constant monitoring of the access status; moreover, a menu structure allows for simple setting of the work timing and the operating logics.

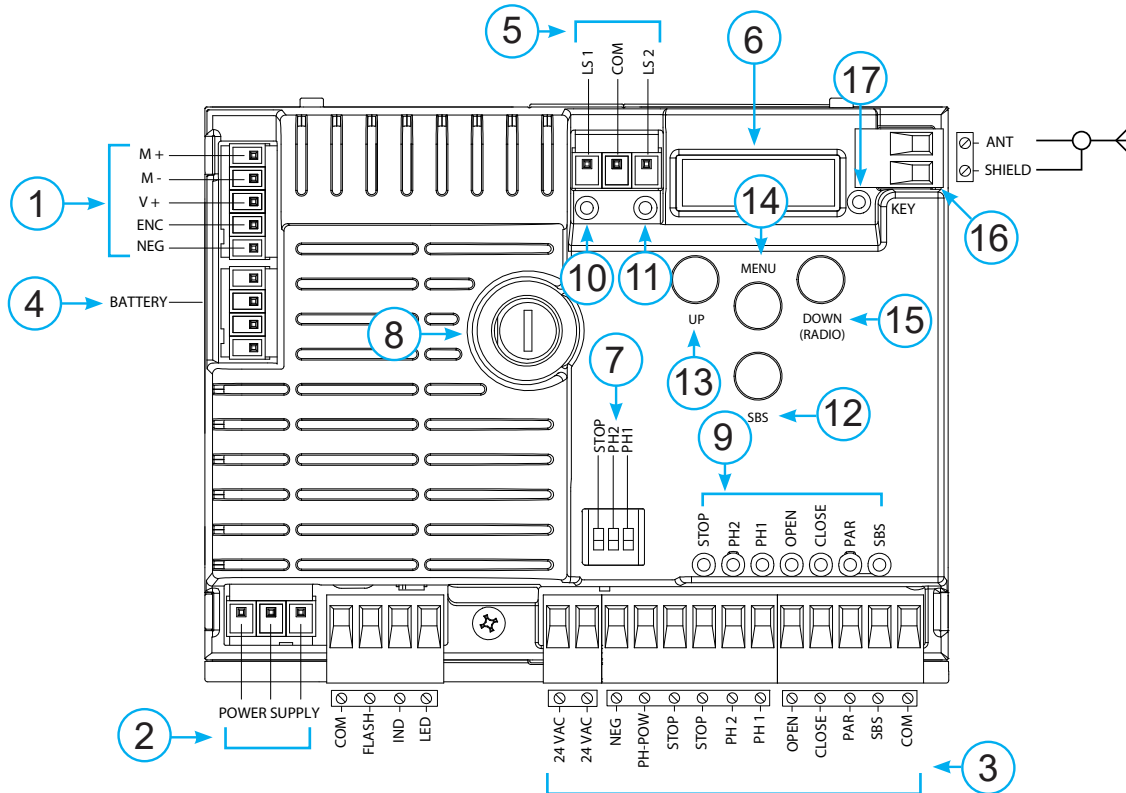

6.2 - Description of the connections

- 1- Motor power supply connections and encoder
- 2- Transformer power supply connections
- 3- 24Vdc and 24Vac output connections to controls and safety devices
- 4- Connector for battery charger KBP
- 5- Limit switch connector
- 6- Functions display
- 7- Safety device dip switch
- 8- Fuse 2A slow-acting
- 9- STOP-PH2-PH1-OPEN-CLOSE-PAR-SBS safety led and led input led

- 10- Limit switch indicator LED LSC
- 11- Limit switch indicator LED LSO
- 12- STEPPING SBS button
- 13- UP + button
- 14- MENU button
- 15- DOWN - button
- 16- Antenna
- 17- KEY led

6.3 - Models and technical characteristics

CODE	DESCRIPTION
900CT10224F	24V control unit for ALT324KF barrier motor
900CT10224	24V control unit for ALT424K and ALT624K barrier motor

- Power supply with protection against short-circuits inside the control unit, on motors and on the connected accessories.
- Obstacle detection.
- Automatic learning of working times.

- Safety device deactivation by means of dip switches: there is no need to bridge the terminals of safety devices which are not installed
- the function is simply disabled by means of a dip switch.

6.4 - Electrical connections

ATTENTION !

Before making the connections, ensure that the control unit is not powered up

MOTOR CONNECTOR

Power supply connection terminal board

M +	Power supply motor
M -	Power supply motor
V +	Power supply encoder
ENC	Encoder signal
NEG	Maximum encoder power supply

POWER SUPPLY CONNECTOR

L	Power supply live 230 Vac (120 Vac) 50-60 Hz
N	Power supply neutral 230 Vac (120 Vac) 50-60 Hz
	Earth

DIP SWITCH

Set on "ON" to disable inputs STOP, PH1, PH2
Eliminates the need to bridge the terminal board inputs.

ATTENTION !

with the dip switch ON,
the safety devices are disabled

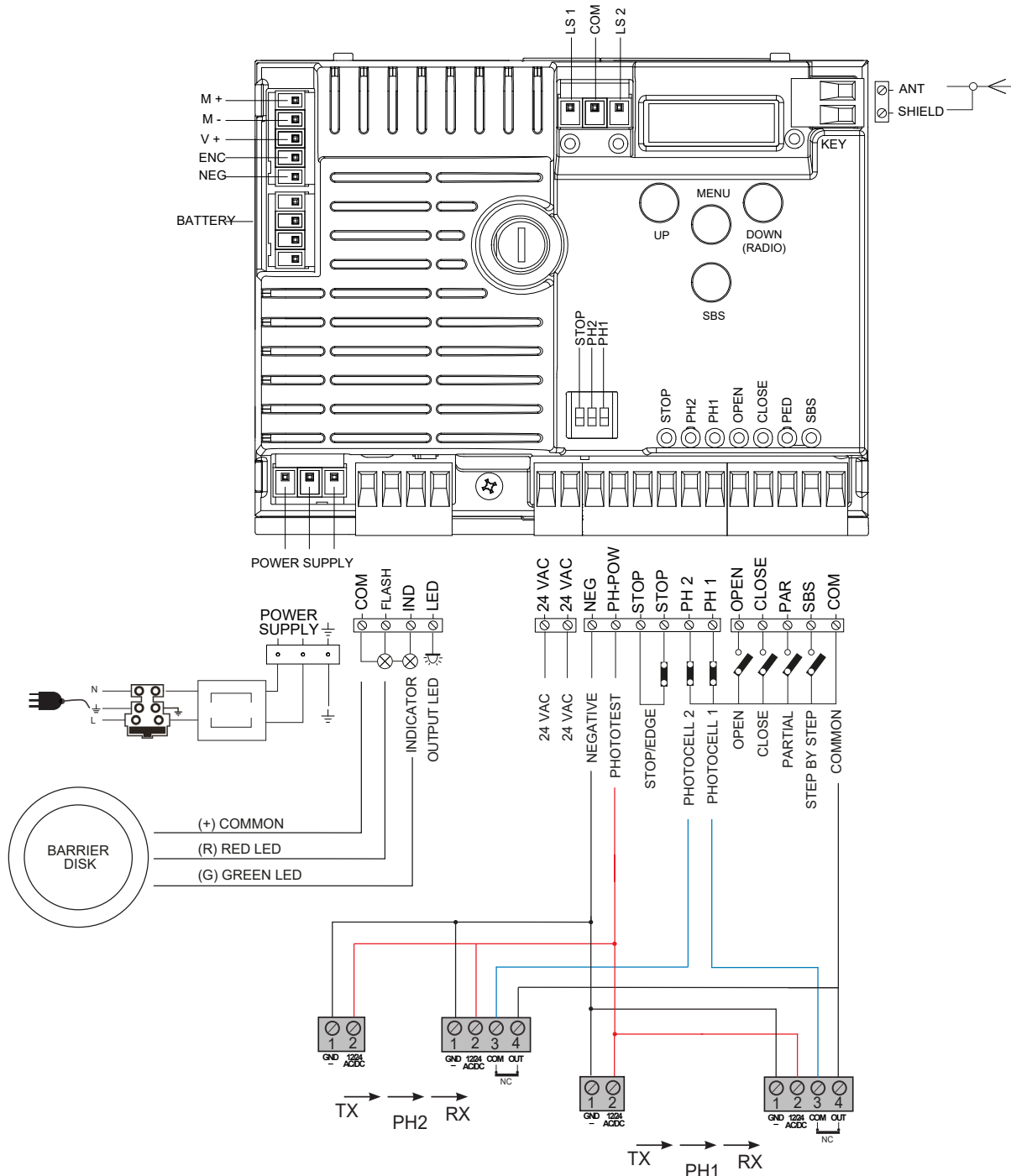
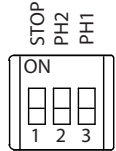

SAFETY AND CONTROL DEVICE CONNECTOR

COM	Common for the FLASH-IND-LED inputs
FLASH	Flashing light output 24Vdc (without regulation), maximum 25W
IND	IND output for barrier open indicator light 24 Vdc not regulated 4W MAX / Electric lock output 12Vac, 15VA maximum selectable with parameter <i>l n.d.</i>
LED	Courtesy light output 24Vdc (without regulation), maximum 25W, controllable also via radio ON-OFF command (radio channel 4 selecting <i>F.L.Y. = 2, t.L.Y. = 0</i>)
24 VAC	Accessories power supply 24 Vac without regulation, 200 mA (with battery operation output not active)
24 VAC	Accessories power supply 24 Vac without regulation, 200 mA (with battery operation output not active)
NEG	Accessories power supply negative
PH-POW	Photocells PH1 and PH2 power supply positive; phototest can be selected with parameter <i>t.P.h.</i> 24 Vdc, 250 mA
STOP	STOP safety device, NC contact between STOP and STOP (warning, with dip switch 1 ON the safety device input is off). This input is classified as a safety device; the contact can be deactivated at any time, cutting out the automation system and disabling all functions, including Automatic Closure. Safety sensor edge, ON/OFF, NC contact or resistive 8K2 between STOP and STOP. Input selectable with parameter <i>E.d.n.</i>
PH2	Photocells (opening), NC contact between PH2 and COM (warning, with dip switch 2 ON the PHOTOCCELL 2 safety device input is off). The photocell is tripped at any time during opening of the automation system, halting operation immediately; the automation system will continue opening when the contact is restored. In the event of intervention on closure (parameter <i>Ph.z. = 0</i>) the device stops and on release re-opens.
PH1	Photocells (closing), NC contact between PH1 and COM (warning, with dip switch 3 ON the PHOTOCCELL 1 safety device input is off) The photocell is tripped at any time during closing of the automation system, halting operation immediately and reversing the travel direction.
OPEN	OPEN command NO contact between OPEN and COM Contact for the HOLD-TO-RUN function. The barrier OPENS as long as the contact is held down
CLOSE	CLOSE command NO contact between CLOSE and COM Contact for the HOLD-TO-RUN function. The barrier CLOSES as long as the contact is held down
SBS	STEPPING command NO contact between SBS and COM Open/Stop/Close/Stop command, or as set in the software
COM	Common for the PH2-PH1-OPEN-CLOSE-PAR-SBS inputs
SHIELD	Antenna - shield -
ANT	Antenna - signal -

6.5 - Display during normal operation

In "NORMAL OPERATING MODE", i.e. when the system is powered up normally, the 3-figure LCD display shows the following status messages:

MESSAGES	MEANING
--	Barrier closed or switch-on after shutdown
OP	Barrier opening
CL	Barrier closing
SO	Barrier stopped during opening
SC	Barrier stopped during closure
F1	Photocell 1 tripped
F2	Photocell 2 tripped
HA	Barrier stopped by external event
ALI	Re-alignment procedure
oP	Barrier stopped without automatic reclosure
-tC	Barrier open with timed reclosure; Flashing dash counting in progress; Dash replaced by figures 0..9 countdown (last 10s)
L--	Learning started on limit switch (move the barrier off the limit switch to continue the learning procedure) or learning stopped due to trip of safety device or motor inversion.
LOP	Learning opening
LCL	Learning closure
rOL	Locked open by radio (available on ALT324KF only)

In addition, the dots between the figures illustrate the status of the limit switches, as described in greater detail below:

MESSAGES	MEANING
-.-	Limit switch CLOSED (one dot between the two lines)
tC.	Limit switch OPEN (a point to the right)
SO	No limit switch active (no dots present)

EVENT	DESCRIPTION	KEY TO MAIN CONTROL FLASHING LIGHT AND KEY LEDS CONTROL UNIT
opening	Barrier opening	
closure	Barrier closing	
automatic closure	Barrier open with timed reclosure active	
stop during closure	Barrier stopped during closure	
stop during opening	Barrier stopped during opening	
open	Barrier completely open without automatic reclosure	
closed	Barrier completely closed	
programmation	During the programming phase	2 quick flashes + pause + 1 flash
obstacle M1	Motor 1 obstacle detected	4 quick flashes + pause, 3 times
photo 1!	Photocell 1 tripped	2 quick flashes + pause, 3 times
photo 2!	Photocell 2 tripped	2 quick flashes + pause, 3 times
sensitive edge!	Sensitive edge tripped	5 quick flashes + pause, 3 times
realignment	Realignment after a manual release	
phototest error	Phototest error detected	3 quick flashes + pause, 3 times
encoder error	Encoder error detected	7 quick flashes

Malfunctions

This section lists a number of malfunctions which may occur.

SURGE OVERLOAD ALARM	The motor's current drawdown has increased very quickly
<i>EOL</i>	<ol style="list-style-type: none"> 1. The barrier has struck an obstacle. 2. Friction on runners or rack (see motor current [A]).
SAFETY EDGE ALARM	The control unit has received a signal from the safety edge
<i>EEd</i>	<ol style="list-style-type: none"> 1. The safety edge has been pressed. 2. The safety edge is not connected correctly.
LIMIT SWITCH ALARM	The limit switches are not working properly
<i>ELS</i>	<ol style="list-style-type: none"> 1. The limit switches are damaged. 2. The limit switches are not connected. 3. Check the travel time which has passed without tripping of the limit switches.
PHOTOCELL ALARM/SAFETY EDGE	Phototest fail outcome.
<i>EPH</i>	<ol style="list-style-type: none"> 1. Check the photocell and the safety edge connections. 2. Check that the photocells and the safety edge are operating correctly.
ENCODER ALARM	Encoder encoder (only if encoder is present)
<i>EE_n</i>	<ol style="list-style-type: none"> 1. Check the encoder connections. 2. Check that the encoder are operating correctly.

After eliminating the cause of the alarm, to delete all errors simply press the "DOWN -" key or press the SBS (STEPPING) command

The display returns to the normal screen.

Press "UP" to read the following parameters on display.

DISPLAY	MEANING
Status display (--, DP, EL, SQ, ecc..)	Description of the control unit (--, DP, EL, SQ, ecc..)
Maneuvers performed	Counter displays alternating the thousands (without dots) and the units (with dots).
Motor current [A]	Current absorbed by the motor

6.6 - Autolearning of the travel stroke

The first time the control unit is powered up, an autolearning procedure must be carried out to acquire fundamental parameters such as the travel stroke length and deceleration points.

AUTOLEARNING OF THE TRAVEL STROKE AND MAIN PARAMETERS

The decelerations will be those set in the menu, with the same percentage during both opening and closing.

1. Release the barrier, move it onto the central position and lock it in place again.
2. Hold down the + and MENU buttons SIMULTANEOUSLY for more than 5 seconds, until the screen shows *LDP* and get ready to press the DOWN key (see illustration) if necessary.
3. If the first operation is NOT opening of the barrier, press the DOWN key to stop the autolearning. Then press SBS to restart the acquisition: the barrier starts moving again, in the right direction. The motor opens the barrier at low speed to the opening limit switch. On reaching the opening limit switch, the barrier restarts in the closing direction at low speed until it reaches the closing limit switch, displaying *LLL*.
4. Perform a number of opening, closing and sudden stop commands to ensure that the system is solid with no assembly defects.

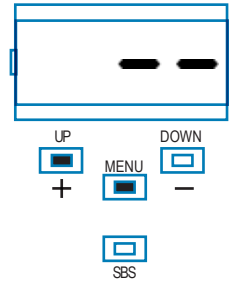

All the main parameters are set with the default settings by the control unit. To customise the installation, proceed as described in point 4.5 below.

6.7 - Learning a transmitter

A transmitter can be "learned" via the specific programming menu or by remote memorisation, using a previously memorised transmitter.

MEMORISING A REMOTE CONTROL

If you are in programming mode exit pressing the MENU button until -- appears. Press the DOWN (RADIO) button for more than 2 seconds. Until the display shows the word "rAd" (radio), then release the button

1. Press and release the DOWN (RADIO) button a number of times equal to the number of the output to be activated: once for output STEP BY STEP, twice for output PARTIAL, three times for output OPEN ONLY, four times for output LIGHT ON/OFF, five times for output PRESET (button A = STEP BY STEP, button B = PARTIAL, button C = OPEN ONLY, button D = LIGHT ON/OFF), six times for output OPEN BISTABLE by radio (available on ALT324KF only).



2. The KEY LED will flash a number of times equal to the number of the output selected, with 1 second pauses between flashes



3. Press the key of the remote control to be memorised within 7 seconds, holding it down for at least 2 seconds



4. If the memorisation has been successful, the KEY LED will give one long flash



5. To memorise another remote control on the same output, repeat point 3

N.B If no commands are given for 7 seconds, the receiver automatically quits the programming mode

DELETING A REMOTE CONTROL

If you are in programming mode exit pressing the MENU button until -- appears. Press the DOWN (RADIO) button for more than 2 seconds. Until the display shows the word "rAd" (radio), then release the button

1. Press the DOWN (RADIO) button until the LED lights up (about 3 seconds)

2. Press the key of the remote control to be deleted within 7 seconds, holding it down until the KEY LED goes out. Release the remote control key

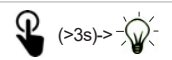

3. About 1 second after the key is released, the KEY LED starts to flash



4. Confirm the deletion by pressing the DOWN (RADIO) button



5. If the deletion has been successful, KEY LED will give one long flash



N.B If no commands are given for 7 seconds, the receiver automatically quits the programming mode



CLEARING THE ENTIRE RECEIVER MEMORY

If you are in programming mode exit pressing the MENU button until -- appears. Press the DOWN (RADIO) button for more than 2 seconds. Until the display shows the word "Fd" (radio), then release the button

1. Press the DOWN (RADIO) button and hold it down until the LED lights up (about 3 seconds) and then goes out (about 3 seconds). Release the key
2. About 1 second after the key is released, the KEY LED starts to flash
3. Press the key on the receiver as the LED flashes for the third time
4. If the deletion has been successful, the KEY LED will give one long flash

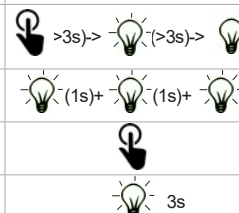

REMOTE MEMORISATION OF A REMOTE CONTROL WITH A REMOTE CONTROL ALREADY MEMORISED

A transmitter can be memorised without accessing the receiver. The user needs to have a transmitter memorised previously, after which the procedure is as described below. The remote copy procedure must be carried out in the area served by the receiver.

1. Press the key of the new remote control to be memorised, holding it down for at least 5 seconds
2. Press the key of the old remote control to be copied (if phase 1 has been successful, the automation system will not respond)
3. Press the key of the new remote control to be memorised, holding it down for at least 3 seconds
4. Press the key of the old remote control to be copied, holding it down for at least 3 seconds, to confirm and quit the programming mode



N.B If no commands are given for 7 seconds, the receiver automatically quits the programming mode

6.8 - Customising the system - BASIC MENU

If necessary, users may select a BASIC MENU which allows modification of the control unit's basic parameters. To select the BASIC MENU proceed as described below.

WARNING: to be certain of accessing the NORMAL OPERATION display state, the starting point for accessing the BASIC MENU, press the MENU key twice

Exampling of modifying a BASIC MENU parameter

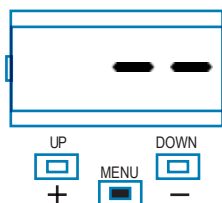

Press the MENU key for 1 second to access the basic menu.

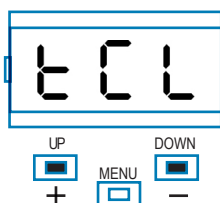

After accessing the BASIC MENU, press the + and - keys to scroll through the functions.

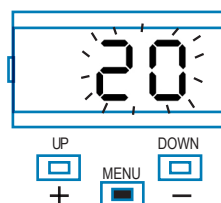

To access the value modification function, press the MENU key for 1 second, until the value starts to flash quickly.

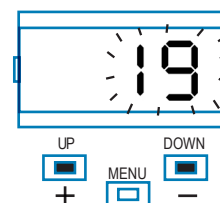

Press the + and - keys to modify the value.

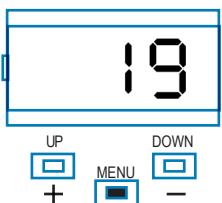

Press the MENU key for 1 second to display the parameter in order to save the modified value, or MENU quickly to quit the function without saving.

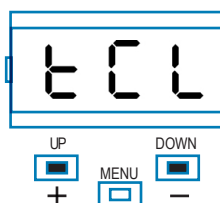

Press the + and - keys to scroll through the functions to modify other parameters.

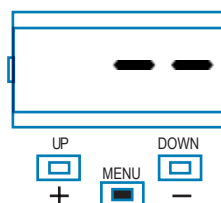

Press the MENU key quickly to quit the menu.

ALT324KF PARAMETERS

PARAMETERS	DESCRIPTION	DEFAULT	MIN	MAX	UNIT	
1	<i>t_{CL}</i>	Automatic reclosure time (0 = off)	0	0	600	0,1 sec
2	<i>t_{tr}</i>	Reclosing time after transit on PH1 (0 = off)	0	0	300	0,1 sec
3	<i>SEI</i>	Sensitivity on obstacles 0 = Maximum impact force 10 = Minimum impact force	3	0	10	
4	<i>SFO</i>	Motor speed during opening 1 = minimum 2 = low 3 = medium 4 = high 5 = maximum	4	1	5	
5	<i>SFC</i>	Motor speed during closing 1 = minimum 2 = low 3 = medium 4 = high 5 = maximum	4	1	5	
6	<i>SbS</i>	STEP BY STEP or SBS configuration: 0 = Normal (AP-ST-CH-ST-AP-ST...) 1 = Alternate STOP (AP-ST-CH-AP-ST-CH...) 2 = Alternate (AP-CH-AP-CH...) 3 = Apartment block – timer 4 = Apartment block with immediate reclosure	4	0	4	
7	<i>LS1</i>	Deceleration distance in opening from 40 to 100 = Motor deceleration percentage during opening	55	40	100	%
8	<i>LS2</i>	Deceleration distance in closing from 40 to 100 = Motor deceleration percentage during closure	68	40	100	%
9	<i>blt</i>	Post blackout procedure 0 = No action, remains stationery 1 = Closure	0	0	1	s
10	<i>Sby</i>	Energy saving: enables photocell switch-off when barrier is closed 0= disabled 1= enabled	0	0	1	

ALT424K/ALT624K PARAMETERS

PARAMETERS	DESCRIPTION	DEFAULT	MIN	MAX	UNIT	
1	t_{CL}	Automatic reclosure time (0 = off)	0	0	900	s
2	t_{tr}	Reclosing time after transit on PH1 (0 = off)	0	0	30	s
3	SEI	Sensitivity on obstacles 0 = Maximum impact force 10 = Minimum impact force	3	0	10	
4	SFO	Motor speed during opening 1 = minimum 2 = low 3 = medium 4 = high 5 = maximum	4	1	5	
5	SSO	Motor speed during opening deceleration phase 1 = minimum 2 = low 3 = medium 4 = high 5 = maximum	1	1	5	
6	SFC	Motor speed during closing 1 = minimum 2 = low 3 = medium 4 = high 5 = maximum	4	1	5	
7	SSC	Motor speed during closing deceleration phase 1 = minimum 2 = low 3 = medium 4 = high 5 = maximum	1	1	5	
8	SBS	STEP BY STEP or SBS configuration: 0 = Normal (AP-ST-CH-ST-AP-ST...) 1 = Alternate STOP (AP-ST-CH-AP-ST-CH...) 2 = Alternate (AP-CH-AP-CH...) 3 = Apartment block – timer 4 = Apartment block with immediate reclosure	4	0	4	
9	LSI	Deceleration distance 0 to 100 = Motor deceleration percentage during opening and closure	20	0	100	%
10	blt	Post blackout procedure 0 = No action, remains stationery 1 = Closure	0	0	1	s
11	Sby	Energy saving: enables photocell switch-off when barrier is closed 0 = disabled 1 = enabled	0	0	1	

7 - FURTHER DETAILS - ADVANCED MENU

ALT324KF ADVANCED MENU

The ADVANCED MENU allows the system to be further customised by modifying parameters not accessible from the basic menu.

To modify ADVANCED MENU parameters, proceed as described for the BASIC MENU.

To access the ADVANCED menu, press the MENU key and hold it down for 5 seconds.

PARAMETERS	DESCRIPTION	DEFAULT	MIN	MAX	UNIT
1	<i>SP.h.</i> Use of PHOTO1 when starting from closed 0 = PHOTO1 is checked 1 = The barrier starts even with PHOTO1 excited 2 = Freeze in close	1	0	2	
2	<i>Ph.2.</i> Use of PHOTO2 0 = Enabled during both opening and closing AP/CH 1 = Only enabled during opening AP	1	0	1	
3	<i>tP.h.</i> Photo-device test 0 = off 1 = PHOTO1 on 2 = PHOTO2 on 3 = PHOTO1 and PHOTO2 on	0	0	3	
4	<i>Ed.n.</i> STOP input selection 0 = STOP contact (NC) 1 = Resistive safety edge (8k2) 2 = Contact safety edge (NC)	0	0	2	
5	<i>iE.d.</i> Sensitive edge tripping mode 0 = only tripped during closure with direction reversal 1 = stops the automation (during both opening and closure) and retreats from the obstacle	0	0	1	
6	<i>tE.d.</i> Edge test 0 = off 1 = on	0	0	1	
8	<i>FP.r.</i> Flashing light output setup 0 = Steady 1 = Flashing 2 = Two-colour LED disk for barrier - barrier closed steady red - barrier open steady green - during opening steady green - during closing steady red - stopped not on limit switch steady red	2	0	2	
9	<i>tP.r.</i> Pre-flashing time (0 = off)	0	0	20	sec
10	<i>FL.Y.</i> (LED output) Courtesy light setup 0 = On at end of operation for time <i>tCY</i> 1 = On if barrier not closed + duration of <i>tCY</i> 2 = On if courtesy light timer (<i>tCY</i>) time not out 3* = Fault detection. Active in case of: - motor overtravel >10 sec - obstacle detection for 3 times - limit switch error - service maintenance reached - encoder error	3	0	3	
11	<i>tCY.</i> Courtesy light on time, if <i>FL.Y.</i> different from 3 (if <i>FL.Y.</i> = 2, <i>tCY.</i> ≥ 1)	0	0	900	sec

* connect between COM and LED. to reset disconnect main power.

PARAMETS	DESCRIPTION	DEFAULT	MIN	MAX	UNIT	
12	<i>l n.d.</i> (active if <i>FP.r.</i> different from 2)	0 = deactivated 1 = barrier open light ON/OFF 2 = barrier open light proportional - Slow flashing with barrier opening - Quick flashing with barrier closing - Steady light if barrier open - 2 flashes + pause with barrier stationary (position other than closed) 3 = Electric lock 4 = Magnetic electric lock function with output active when barrier is closed	0	0	4	
13	<i>SE.r.</i>	Service interval cycle threshold. (0 = off)	50	0	200	x 10.000 cycles
14	<i>SE.F.</i>	Enabling of continuous flashing indicating service required with <i>SE.r.</i> ≠ 0 (only active with barrier closed). 0 = off 1 = on	1	0	1	
15	<i>St.P.</i>	High-speed motor start-up. 0 = on 1 = off	1	0	1	
16	<i>dE.F.</i>	1 = Restore of factory settings for sliding barrier motor ALT324KF	1	0	1	

To set the default values: 1) access the advanced programming function; 2) select the "dEF" parameter"; 3) activate the modification mode ("0" on display"); 4) accept the modification (press "MENU"

and hold it down). A countdown should now appear: 49,48...,1 down to "don". Release the key when finished.

ALT424K/ ALT624K ADVANCED MENU

The ADVANCED MENU allows the system to be further customised by modifying parameters not accessible from the basic menu.

To modify ADVANCED MENU parameters, proceed as described for the BASIC MENU.

To access the ADVANCED menu, press the MENU key and hold it down for 5 seconds.

PARAMETS	DESCRIPTION	DEFAULT	MIN	MAX	UNIT
1	<i>SP.h.</i> Use of PHOTO1 when starting from closed 0 = PHOTO1 is checked 1 = The barrier starts even with PHOTO1 excited	1	0	1	
2	<i>Ph.2.</i> Use of PHOTO2 0 = Enabled during both opening and closing AP/CH 1 = Only enabled during opening AP	1	0	1	
3	<i>tP.h.</i> Photo-device test 0 = off 1 = PHOTO1 on 2 = PHOTO2 on 3 = PHOTO1 and PHOTO2 on	0	0	3	
4	<i>Ed.n.</i> STOP input selection 0 = STOP contact (NC) 1 = Resistive safety edge (8k2) 2 = Contact safety edge (NC)	0	0	2	
5	<i>iE.d.</i> Sensitive edge tripping mode 0 = only tripped during closure with direction reversal 1 = stops the automation (during both opening and closure) and retreats from the obstacle	0	0	1	
6	<i>tE.d.</i> Edge test 0 = off 1 = on	0	0	1	
9	<i>FP.r.</i> Flashing light output setup 0 = Steady 1 = Flashing 2 = Two-colour LED strip for barrier (MODE 1) - barrier closed steady red - barrier open LEDs off - during opening flashing green - during closing flashing red - stopped not on limit switch flashing red 3 = two-colour LED strip for barrier (MODE 2) - barrier closed steady red - barrier open steady green - during opening flashing green - during closing flashing red - stopped not on limit switch flashing red N.B.: if this parameter is set as 2 or 3, the settings of parameter <i>i n.d.</i> will be ignored. If this parameter is set as 2 or 3, the flashing light and barrier open light outputs will be used for operation with the LED strip	3	0	3	
10	<i>tP.r.</i> Pre-flashing time (0 = off)	0	0	20	s
11	<i>FC.y.</i> Courtesy light setup 0 = On at end of operation for time <i>tCY</i> 1 = On if barrier not closed + duration of <i>tCY</i> 2 = On if courtesy light timer (<i>tCY</i>) time not out	0	0	2	
12	<i>tCY.</i> Courtesy light on time (if <i>FC.y.</i> = 2, <i>tCY.</i> ≥ 1)	0	0	900	s
13	<i>CL.E.</i> Clearance. Allows to stop before the fully open position: it is useful to avoid mechanical stress during opening.	0	0	30	%
14	<i>dE.A.</i> Hold-to-run 0 = off 1 = on	0	0	1	

PARAMETS	DESCRIPTION	DEFAULT	MIN	MAX	UNIT
15	<i>l n.d.</i> 0 = deactivated 1 = barrier open light ON/OFF 2 = barrier open light proportional - Slow flashing with barrier opening - Quick flashing with barrier closing - Steady light if barrier open - 2 flashes + pause with barrier stationary (position other than closed) 3 = Electric lock 4 = Magnetic electric lock function with output active when barrier is closed N.B. interface with an external relay with 24 Vdc winding. To activate this function, the pre-flash must be enabled at the recommended value of 1 sec (<i>tP.r.</i> ≠ 0) 5 = LED strip for barrier open light (MODE 1) - steady light when open and closed - flashing light in all other positions 6 = LED strip for barrier open light (MODE 2) - barrier closed steady red - barrier open LEDs off flashing red in all other positions	0	0	6	
16	<i>SE.r.</i> Service interval cycle threshold. (0 = off)	10	0	200	x 1000 cycles
17	<i>SE.F.</i> Enabling of continuous flashing indicating service required with <i>SE.r.</i> ≠ 0 (only active with barrier closed). 0 = off 1 = on	0	0	1	
18	<i>EL.t.</i> Electric lock activation time in seconds	4	1	10	s
19	<i>St.P.</i> High-speed motor start-up. 0 = on 1 = off	0	0	1	
21	<i>nE.P.</i> 1 to 10 pulses per revolution of the physical encoder	4	1	10	
22	<i>dE.F.</i> 0 = Restore of factory settings for sliding barrier motor SC4224 1 = Restore of factory settings for sliding barrier motor SUN4224 2 = Restore of factory settings for sliding barrier motor SUN7224, SC7224 3 = Restore of factory settings for sliding barrier motor SUN11224, SC11224 4 = Factory setting restore for 4/6 mt barrier and up-and-over door 5 = Factory setting restore for 8 mt barrier	0	0	5	

To set the default values: 1) access the advanced programming function; 2) select the "dEF" parameter"; 3) activate the modification mode ("0" on display"); 4) accept the modification (press "MENU" and hold it down). A countdown should now appear: 49,48...,1 down to "d00". Release the key when finished.

To use both colours of a two-colour LED strip, make the connections as explained in the CTLIGHT2 instructions and modify parameters *FP.r.* as required (setting 2 or 3).

To use just one colour of a LED strip, make the connections as explained in the CTLIGHT2 instructions and modify parameter *l n.d.* as required (setting 5 or 6); parameter *FP.r.* cannot be set on 2 or 3.

8 - TESTING AND COMMISSIONING THE AUTOMATION SYSTEM

The system must be tested by a qualified technician who must carry out the tests required by the applicable standard according to the existing risks, ensuring compliance with the standard provisions, in

particular the EN12453 standard which specifies the test methods to be applied to the motorized doors

8.1 - Testing

All system components must be tested following the procedures described in their respective operator's manuals;

ensure that the recommendations in Chapter 1 - Safety Warnings - have been complied with;

Check that the bar can move freely once the automation system is released and that it remains stationary and balanced if left at a 45° angle

Check the correct operation of all the connected devices (photocells, sensitive edges, emergency buttons, others) by carrying out barrier opening, closing and stopping tests via the connected control devices (transmitters, buttons, selector switches)

Perform the impact measurements as required by the EN12453 standard, adjusting the control unit's speed, motor force and deceleration functions if the measurements do not give the required results, until the correct setting is obtained.

8.2 - Commissioning

Once all (and not just some) of the system devices have passed the testing procedure, the system can be commissioned;

The system's technical dossier must be produced and kept for 10 years. It must contain the electrical wiring diagram, a drawing or photograph of the system, the analysis of the risks and the solutions adopted to deal with them, the manufacturer's declaration of conformity for all connected devices, the operator's manual for every device and the system maintenance plan;

Fix to the barrier lift body a data plate indicating the automation data, the name of the person in charge of commissioning, the serial number and the year of construction, and the CE mark

Also fit a sign specifying the procedure for releasing the system by hand;

Draw up the declaration of conformity, the instructions and precautions for use for the end user and the system maintenance plan and consign them to the end user;

Ensure that the user has fully understood how to operate the system in automatic, manual and emergency modes;

The end user must also be informed in writing about any risks and hazards still present.

9 - MAINTENANCE

The automation systems for ALT road barriers are designed and manufactured to high quality standards. However, like any other machine, regular maintenance is required to ensure safety and maximise durability.

System maintenance must be carried out by qualified technicians, in full compliance with the safety standards required by current laws.

Before carrying out maintenance disconnect any electrical power supply, including any backup batteries.

A few precautions and checks to be carried out at regular intervals will ensure efficiency, longer working life and reliable operation of safety systems.

9.1 - Maintenance schedule

We recommend to carry out a general ALT automation system check every 6 months or every 50,000 opening/closing cycles. In the case of systems submitted to intensive use, the frequency of inspections should be doubled.

Please note the following points, which should be intended as a general guide to the operations to be performed at regular intervals in order to keep the automation system efficient, safe and in good operating conditions:

1. Perform a general external inspection of the automation system, checking the state of wear of the materials, paying particular attention to signs of corrosion and/or cracks in the outer casing.

2. Check for bar integrity, making sure that there are no deformations and/or cracks, particularly in the area where the bar is attached to the barrier support plate. Check the integrity of the "omega" shaped bar-holding bracket and the tightening of the bracket fixing screws to the plate connected to the output shaft. Make sure that there is no clearance such as to affect safety.

3. Check the integrity and efficiency of the PROFT rubber shock protection profile with respect to the bar. A rubber profile partially damaged or cracked, or not adequately fixed, will not effectively ensure shock protection, affecting the safety of the automation system.

4. In versions of bars formed by segments joined together by a joint, check for perfect fastening and alignment of the two segments. You may want to adjust the expansion bolts of the joint to restore the correct interference and alignment. If, despite the adjustment, it is no longer possible to return the bar to its optimal condition, replace it altogether (kits ASTL4J, ASTL6J, ASTL8).

5. After removing the door of the barrier body, carry out a general internal inspection of the system, checking the state of wear/damage of all the materials making up the automation system, paying particular attention to corrosion and/or cracks in the structural parts: replace any components showing signs of wear.

6. Check the ground anchoring stability of the automation system; check the tightness of the nuts of the anchoring clamps/tie-rods of the base plate of the cabinet and the integrity of the perimeter welds of the outer casing with respect to the plate.

7. Check that all screw-down connections are tight as required. In particular, check:

- The tightening of the bolts and nuts securing the ball joint heads of the top spring tensioners with respect to the balancing lever
- on ALT3/ALT6, the tightening of the top and bottom articulated heads of the vertical hexagonal lever connecting the motor lever to the balancing lever
- the tightening of the lock nuts of the top spring tensioner articulated heads with respect to the threaded bars
- on ALT4, the tightening of the balancing lever fixing screw with respect to the drive shaft
- on ALT3/ALT6, the tightening of the motor lever fixing screw with respect to the drive shaft
- tightening of the gearmotor fixing screws to the cabinet
- on ALT3/ALT6, the tightening of the fixing screws of the support

flanges of the output shaft rear bearing
- ALT3/ALT6, the tightening of the fixing screws of the support collars of the output shaft front bearing

8. On ALT6, check the tightening of the countersunk screw fixing the bar support plate to the square shaft (Fig. 14)

9. On ALT3/ALT6 check the articulated heads of the connecting rod M12 and of the tensioners M10, making sure that they are not worn and that there is no slack in their movement. If this is the case, replace them

10. Lubricate the articulated heads of the spring tensioners and the vertical hex lever with fluid oil or spray grease.

11. Check the integrity and adjustment of the bar end stops (see paragraph 5.4 "Bar angle adjustment"). If the screws are worn and/or deformed, replace them with hex head screws M10x35.

12. With the bar in the closed position, check that the pitch between the turns of the balancing spring(s) is regular and constant, without any deformation suggestive of yield stress. If this is the case, replace the spring(s) (see also paragraph 9.2 "Replacement schedule").

13. Remove the plastic cover of the control unit box and check that there are no signs of overheating/burning of the connecting cables, connectors and electronic components making up the board.

14. Check the function of the unlocking system: with the bar in a closed position, manually release the gearmotor (see paragraph 5.3 "Bar unlocking") checking that this is done easily. When the bar is released, check that it is easy to shift it by hand between its open and closed positions, without experiencing any jamming. Check that the strength required to move the bar during opening, measured perpendicularly to the bar and 1 m from the axis of rotation, does not exceed 220 N (about 22 kg).

15. When the bar is released, check that it is correctly balanced at 45°, adjusting the tension of the spring(s) if necessary by loosening the lock nut and working the tensioner (see paragraph 5.10 "Bar balancing"). After completing the balancing operations, re-tighten the lock nut to prevent unintentional loosening of the tensioner.

16. After locking the bar again, using the control devices (control button, transmitter, selectors, etc.), carry out tests for opening, closing and stopping the bar, making sure that the movement matches the expectations. Check that the angle of the bar is correct, adjusting the bar end stops if required (see paragraph 5.4 "Adjustment of the bar angle") and, if necessary, carry out the self-learning procedure for the travel and main operating parameter values once again (see paragraph 6.6 "Travel self-learning").

17. Check, one by one, all the safety devices present in the system (photocells, sensitive edges, emergency buttons, etc.) to ensure their efficiency. Make sure that the photocells are securely fixed to their supports and check the integrity of the lids/lenses. Thoroughly clean their front surface (do not use solvents).

18. Check the efficiency of the LED flashing lights integrated in the barrier body and the integrity of the transparent covers.

standard (see paragraph 8.1 "Testing")

19. Check the integrity and efficiency of any accessories installed: APM mobile support, APFX fixed support, SKIRT2 racks, joint for articulated bar, etc. Make sure that they are firmly secured.

20. Check that the automation system is working properly and that the bar motion is smooth. Ensure that the opening and closing speeds are adequate for the length of the bar, with gradual acceleration in the initial phase and progressive slowing down in the final phase of the travel, in order to avoid dangerous jolts and swaying that could affect the safety and life of the bar.

21. Ensure compliance with the regulation provisions, in particular the requirements relating to user safety contained in the EN 12453

9.2 - Scheduled replacements

The components that make up the ALT automation system have been designed to last, under normal conditions of use, for the entire working life of the product without any special action being required.

However, some of them are directly linked to system safety and therefore, it is recommended to regularly replace them according to the following indications:

1. Replace the balancing spring(s) every 2 years or every 200,000 opening/closing cycles

2. Replace:

- the aluminium bar AST3F, ASTL4, ASTL4J, ASTL6, ASTL6J every 5 years or every 500,000 opening/closing cycles

- the aluminium bar ASTL5, ASTL8 every 3 years or every 250,000 opening/closing cycles

- the articulated bar AS-SNO3 every 2 years or every 150,000 opening/closing cycles

3. Replace the gearmotor every 5 years or every 500,000 opening/closing cycles

NOTES

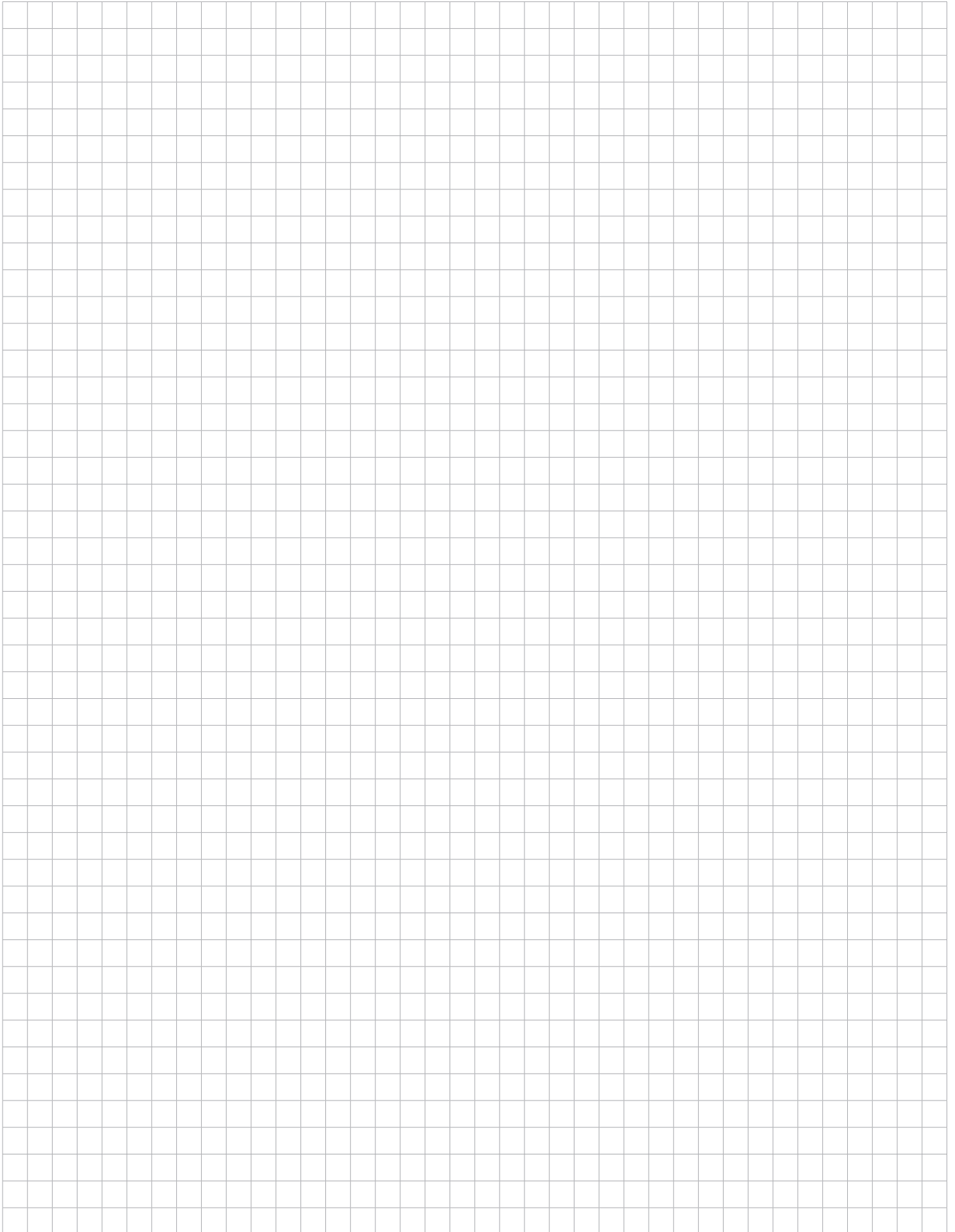

10 - INSTRUCTIONS AND WARNINGS FOR THE END USER

Key Automation S.r.l. produces systems for the automation of gates, garage doors, automatic doors, roller blinds and car-park and road barriers. However, Key Automation is not the manufacturer of your complete automation system, which is the outcome of the analysis, assessment, choice of materials and installation work of your chosen installer. Every automation system is unique, and only your installer has the experience and skill required to produce a safe, reliable, durable system tailored to your needs, and above all that complies with the relevant regulatory standards. Although your automation system complies with the regulation safety level, this does not rule out the presence of "residual risk", meaning the possibility that hazards may occur, usually due to reckless or even incorrect use. We would therefore like to give you some advice for the correct use of the system:

- before using the automation system for the first time, have the installer explain the potential causes of residual risks to you;
- keep the manual for future reference, and pass it on to any new owner of the automation system;
- reckless use and misuse of the automation system may make it dangerous: do not operate the automation system with people, animal or objects within its range of action;
- a properly designed automation system has a high level of safety, since its sensor systems prevent it from moving with people or obstacles present so that its operation is always predictable and safe. However, as a precaution children should not be allowed to play close to the automation system, and to prevent involuntary activation, remote controls must not be left within their reach;
- as soon as any system malfunction is noticed, disconnect the electricity supply and perform the manual release procedure. Never attempt repairs on your own; call in your installation engineer. In the meantime the door or gate can be operated without automation once the geared motor has been released using the release key supplied with the system. In the event of safety devices out of service arrange for repairs to the automation immediately;
- in the event of malfunctions or power failures: while waiting for the engineer to come (or for the power to be restored if your system is not equipped with buffer batteries), the door or gate can be used just like any non-automated installation. To do this, the manual release procedure must be carried out;
- Manual movement and release: before carrying out this operation, note that the release can only take place when the bar is stationary.

- Maintenance: Like any machine, your automation system needs regular periodic maintenance to ensure its long life and total safety. Arrange a periodic maintenance schedule with your installation engineer. Key Automation recommends that maintenance checks should be carried out every six months for normal domestic use, but this interval may vary depending on the level of use. Any inspection, maintenance or repair work must only be carried out by qualified staff.

- Never modify the automation system or its programming and setup parameters: this is the responsibility of your installation engineer.

- Testing, routine maintenance and any repairs must be recorded by the person who performs them and the documents must be conserved by the system's owner.

The only service actions that may and should be regularly carried out are cleaning of the photocell lenses and removal of any leaves that could impair their function. To prevent someone from operating the barrier, before cleaning remember to unlock it and use only a cloth slightly dampened with water to wipe it.

- At the end of its useful life, the automation system must be dismantled by qualified personnel, and the materials must be recycled or disposed of in compliance with the legislation locally in force.

- Activate the barrier control (with the remote control, with the key selector, etc.); if everything is in order the barrier will open or close normally, otherwise the flashing light will flash a few times and the operation will not start.

With the safeties out of use, the automation must be repaired as soon as possible.

If after some time your remote control seems to have become less effective, or stops operating completely, the battery may be flat (depending on the level of use, this may take from several months up to more than a year). You will realise this because the transmission confirmation light does not come on, or only lights up for a very short time.

Batteries contain pollutants: do not dispose of them with normal waste but follow the methods specified by the local regulations.

Thank you for choosing Key Automation S.r.l.; please visit our Internet site www.keyautomation.com for further information.

Sblocco dell'asta

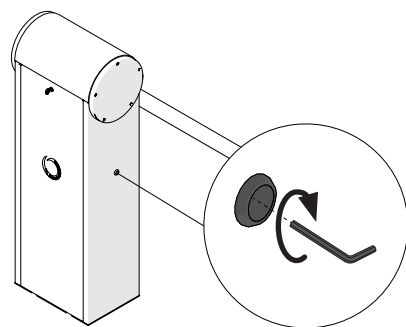
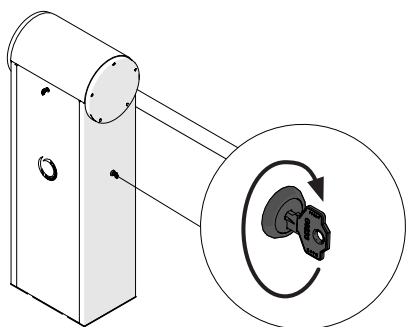

NOTES

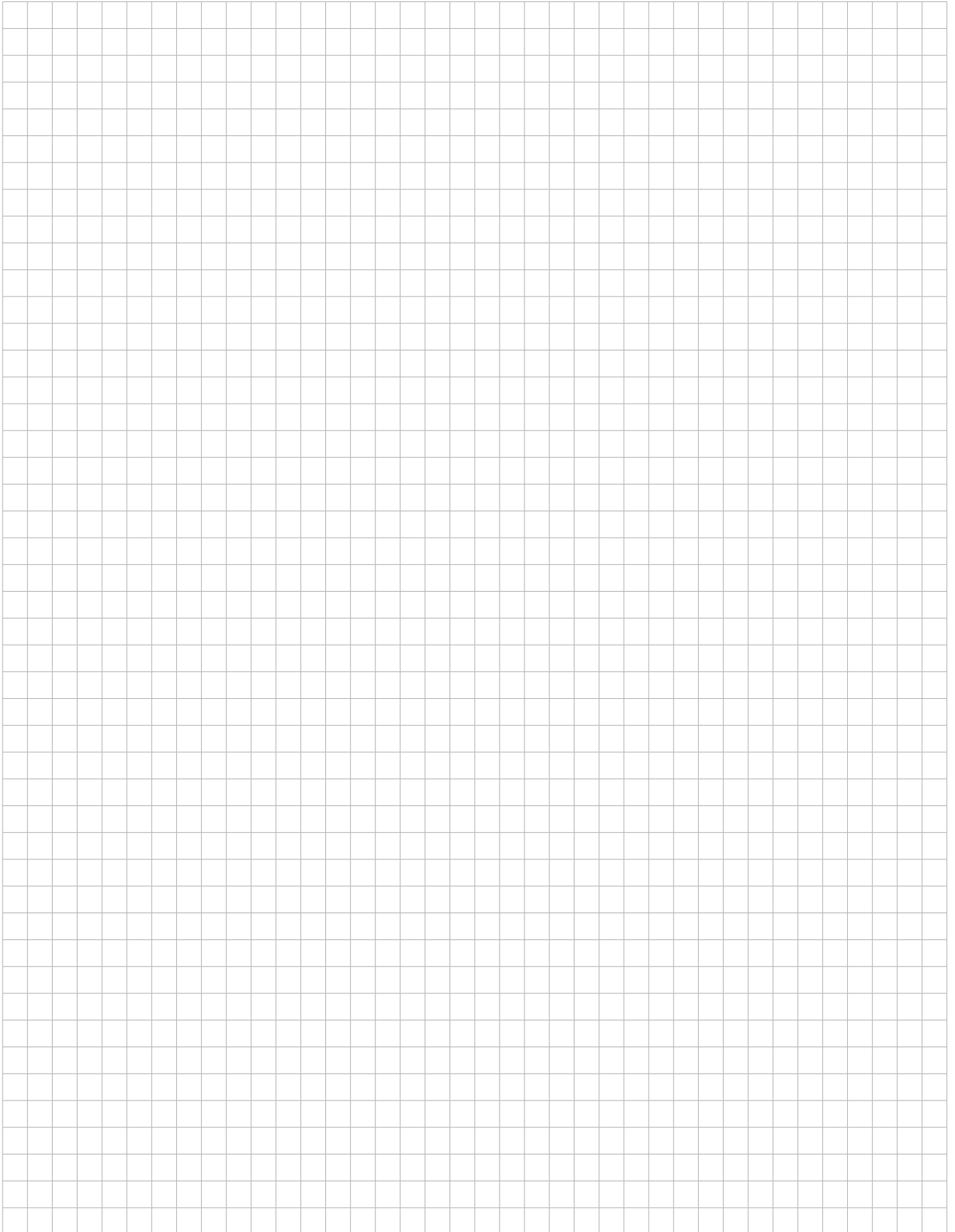

Fig. 1 IT - Descrizione e componenti

EN - Description and components

FR - Description des composants

ES - Descripción y componentes

DE - Beschreibung und Komponenten

PT - Descrição e componentes

PL - Opis i części składowe

ALT324KF

ALT424K

ALT624K

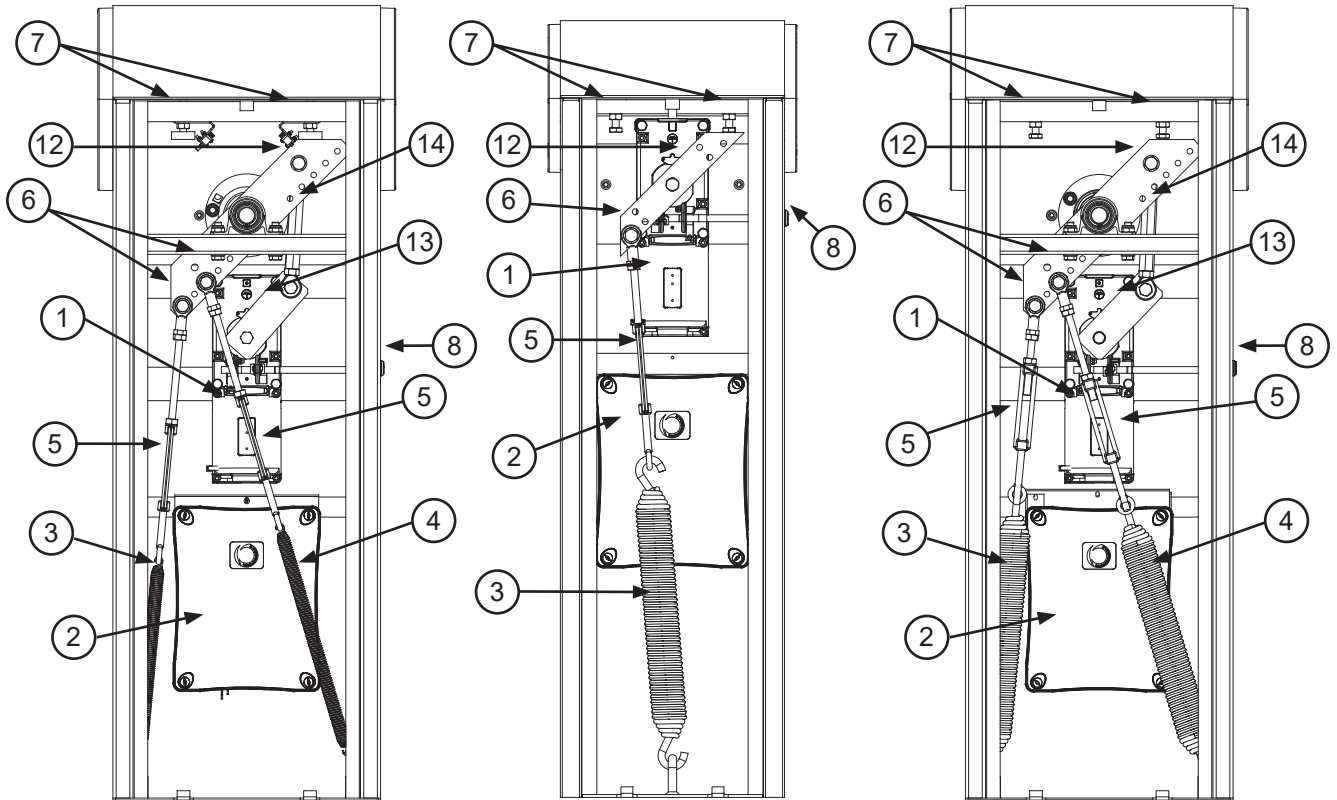

COMPONENTI PRINCIPALI

1	MOTORIDUTTORE 24 Vdc
2	CENTRALE DI COMANDO
3	MOLLA VERTICALE
4	MOLLA DIAGONALE
5	TENDITORE
6	TESTE A SNODO TENDITORE
7	BATTUTE FINECORSA
8	CHIAVE DI SBLOCCO
9	ASTA
10	STAFFA REGGI-ASTA
11	PIASTRA DI SUPPORTO
12	LEVA A BILANCIERE
13	LEVA MOTORE
14	BIELLA DI COLLEGAMENTO

MAIN COMPONENTS

1	24 Vdc GEARMOTOR
2	CONTROL UNIT
3	VERTICAL SPRING
4	DIAGONAL SPRING
5	TENSIONER
6	TENSIONER JOINT HEADS
7	LIMIT STOPS
8	RELEASE KEY
9	ROD
10	BAR-HOLDING BRACKET
11	SUPPORT PLATE
12	BALANCING LEVER
13	MOTOR LEVER
14	CONNECTING ROD

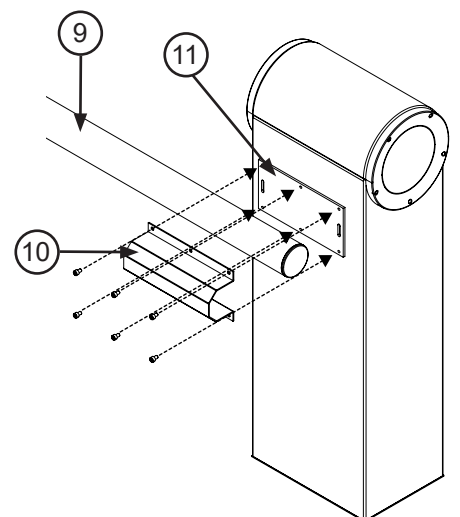

Fig. 2 IT - Dimensioni d'ingombro
 EN - Overall dimensions
 FR - Dimensions hors-tout
 ES - Medidas exteriores máximas

DE - Außenmaße
 PT - Dimensões
 PL - Wymiary gabarytowe

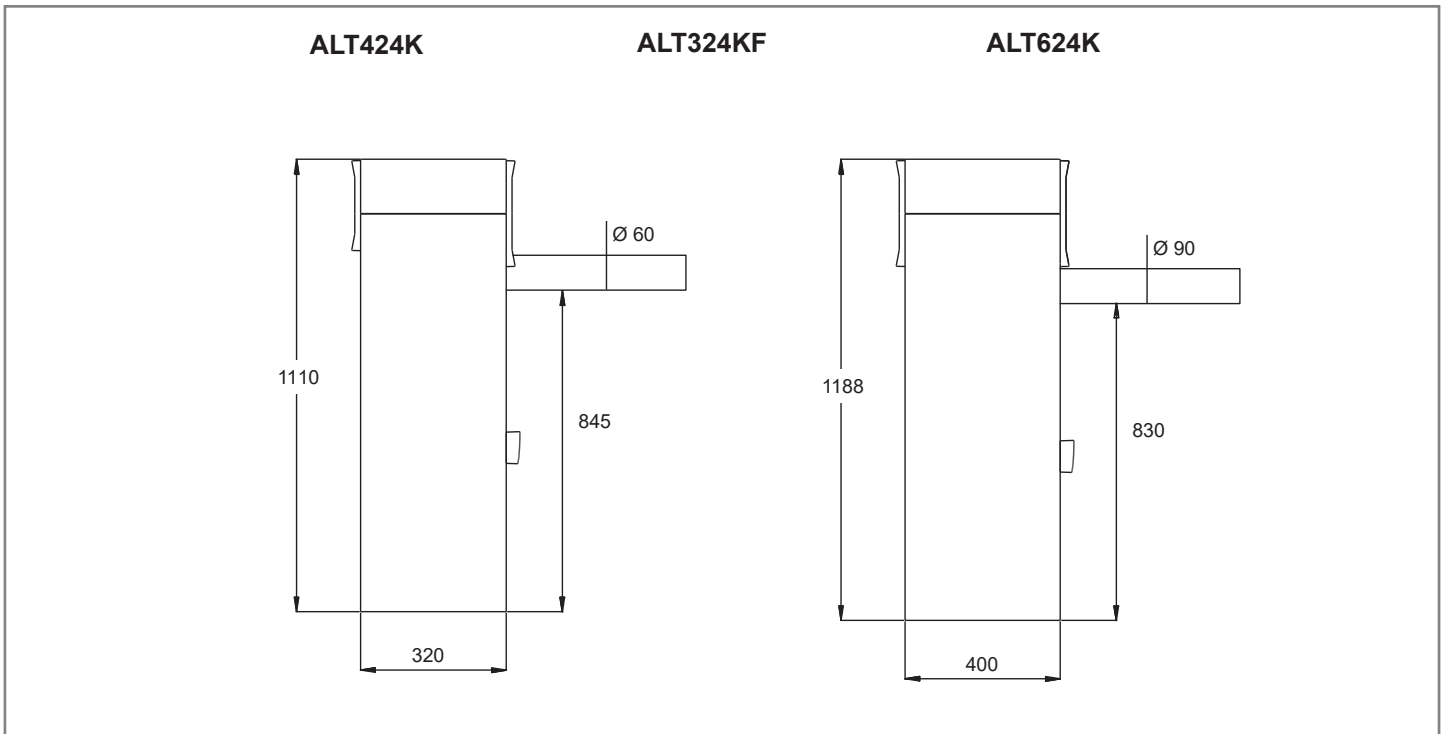

Fig. 3 IT - Installazione tipica
 EN - Standard installation
 FR - Installation type
 ES - Instalación típica

DE - Typische Installation
 PT - Instalação padrão
 PL - Typowy montaż

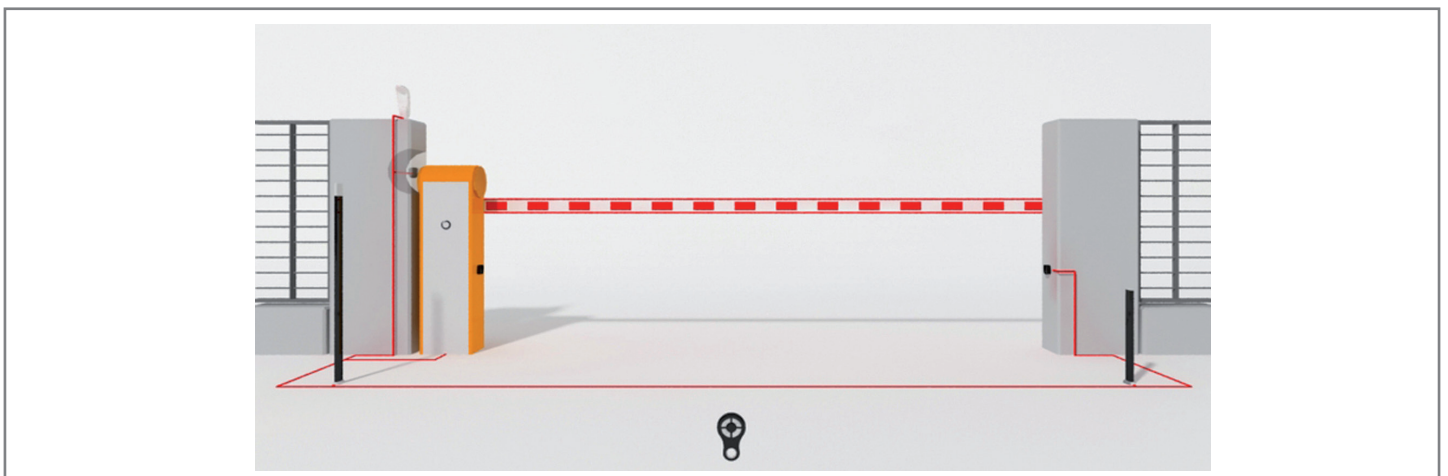

Fig. 4 IT - Fissaggio barriera
 EN - Barrier fixing
 FR - Fixation barrière
 ES - Fijación de la barrera

DE - Schrankenbefestigung
 PT - Fixação da barreira
 PL - Mocowanie szlabanu

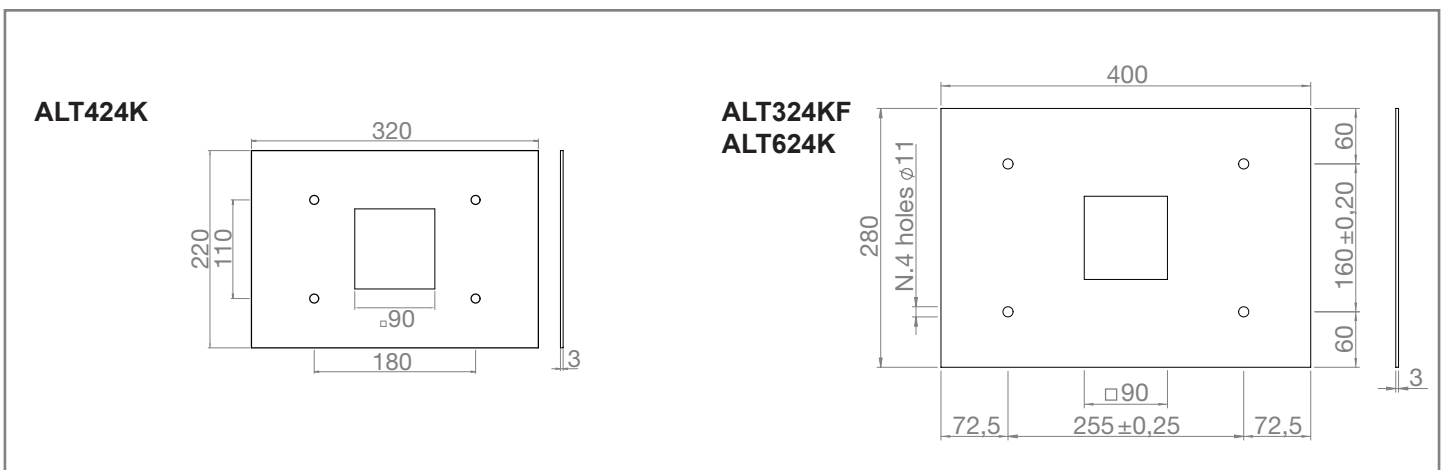

Fig. 5 IT - Preparazione della base
 EN - Preparation of the base
 FR - Préparation de la base
 ES - Preparación de la base

DE - Vorbereitung der Basis
 PT - Preparação da base
 PL - Przygotowanie podstawy

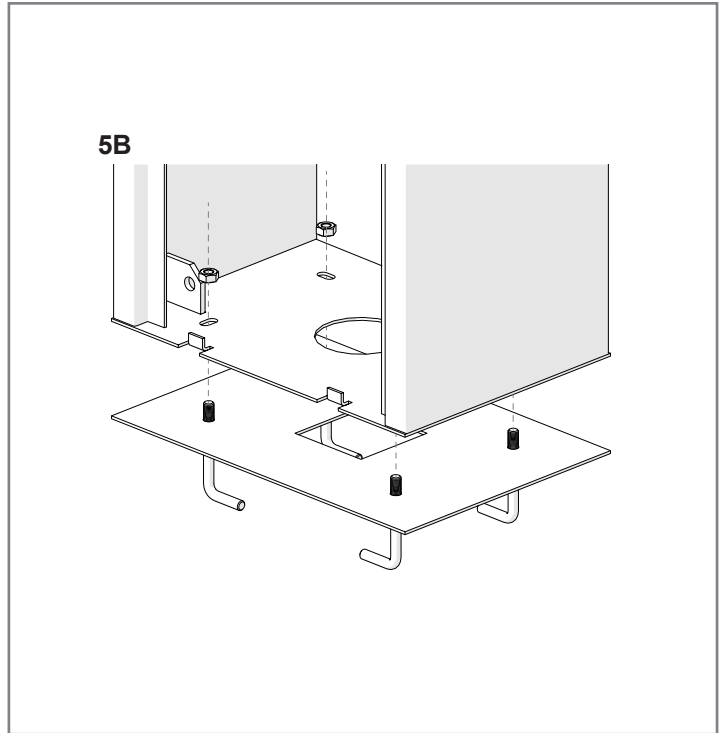
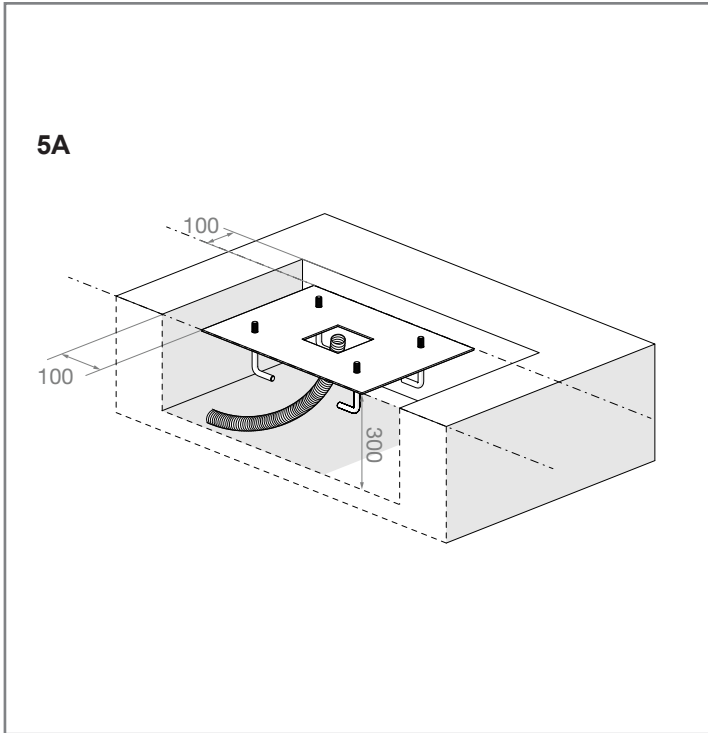

Fig. 6 IT - Inversione senso di apertura
 EN - Reversal of opening direction
 FR - Inversion du sens d'ouverture
 ES - Inversión de la dirección de apertura

DE - Umkehr der Öffnungsrichtung
 PT - Inversão do sentido de abertura
 PL - Odwrócenie kierunku otwierania

FACTORY CONFIGURATION

IT
TIPI DI MOLLE
 1=molla + tirante corto
 2=molla + tirante lungo

EN
SPRING TYPE
 1=spring + short tie rod
 2=spring + long tie rod

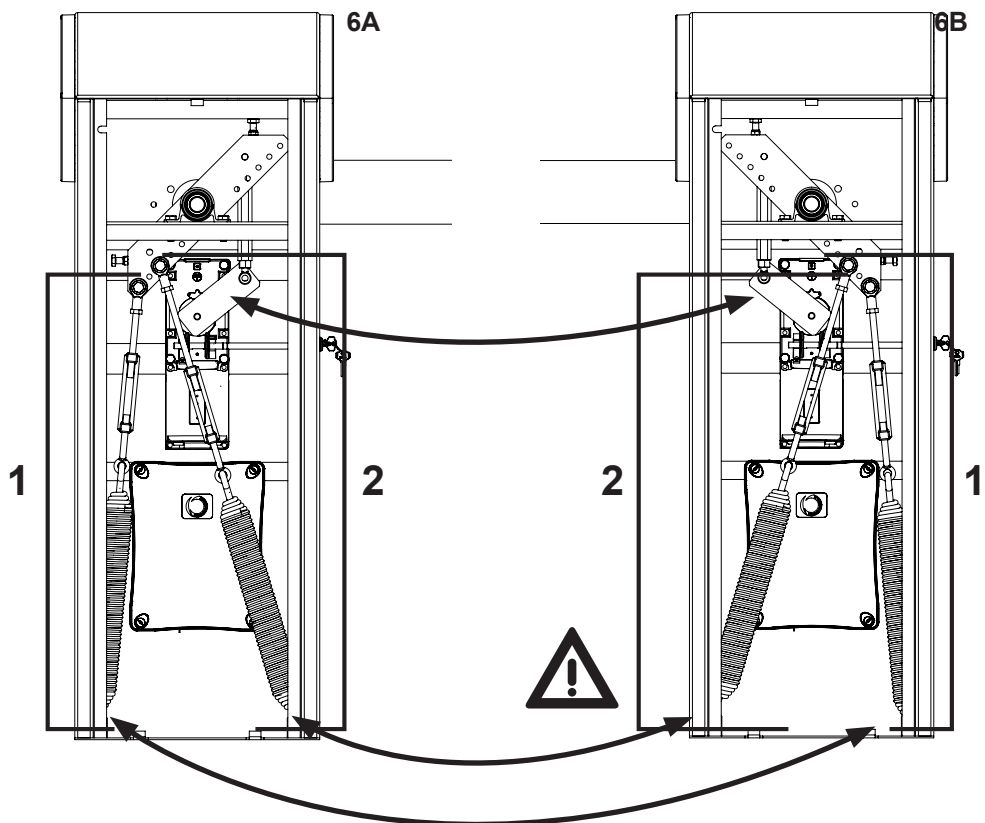

Fig. 7 IT - Apertura della porta frontale
 EN - Front door opening
 FR - Ouverture de la porte frontale
 ES - Apertura de la tapa frontal

DE - Öffnung der vorderen Abdeckung
 PT - Abertura da porta frontal
 PL - Otwieranie drzwi przednich

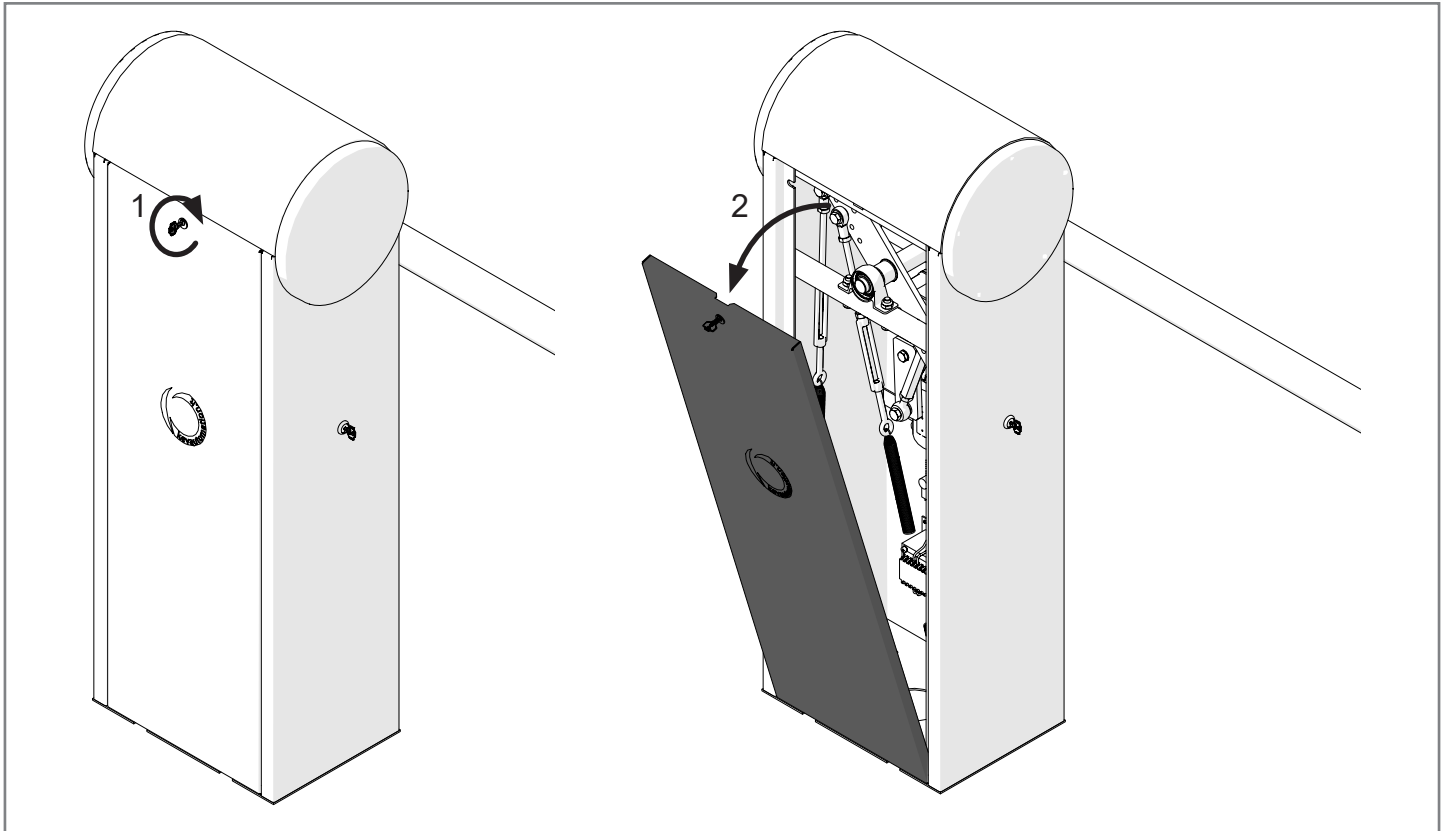

Fig. 8 IT - Rimozione molle
 EN - Spring removal
 FR - Dépose ressorts
 ES - Extracción de los muelles

DE - Entfernung der Federn
 PT - Remoção das molas
 PL - Demontaż sprężyn

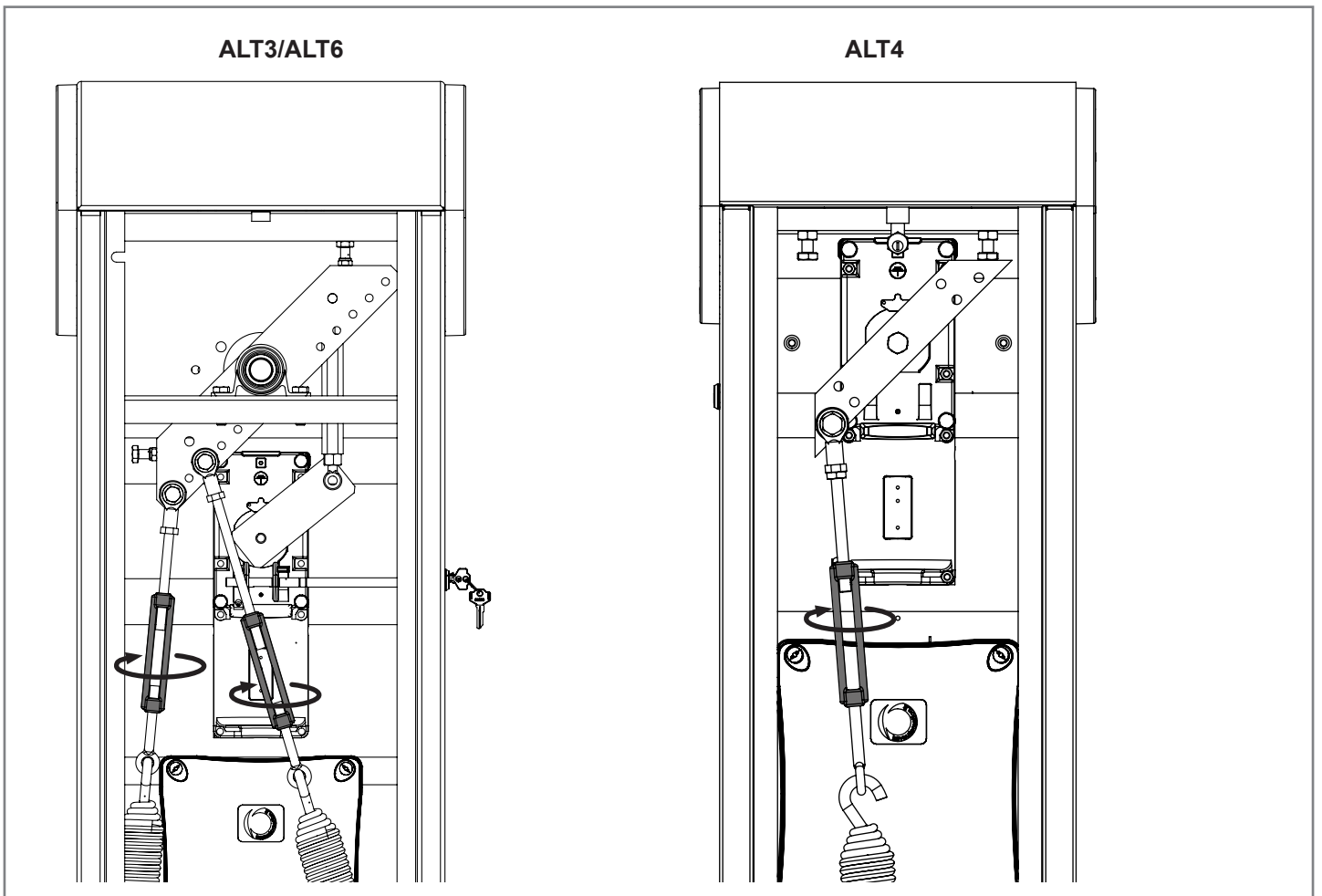

Fig. 9 IT - Rimozione biella di collegamento
 EN - Connecting rod removal
 FR - Dépose bielle de liaison
 ES - Extracción de la biela de conexión

DE - Entfernung des Verbindungspleuels
 PT - Remoção da biela de ligação
 PL - Demontaż korbowaodu łączącego

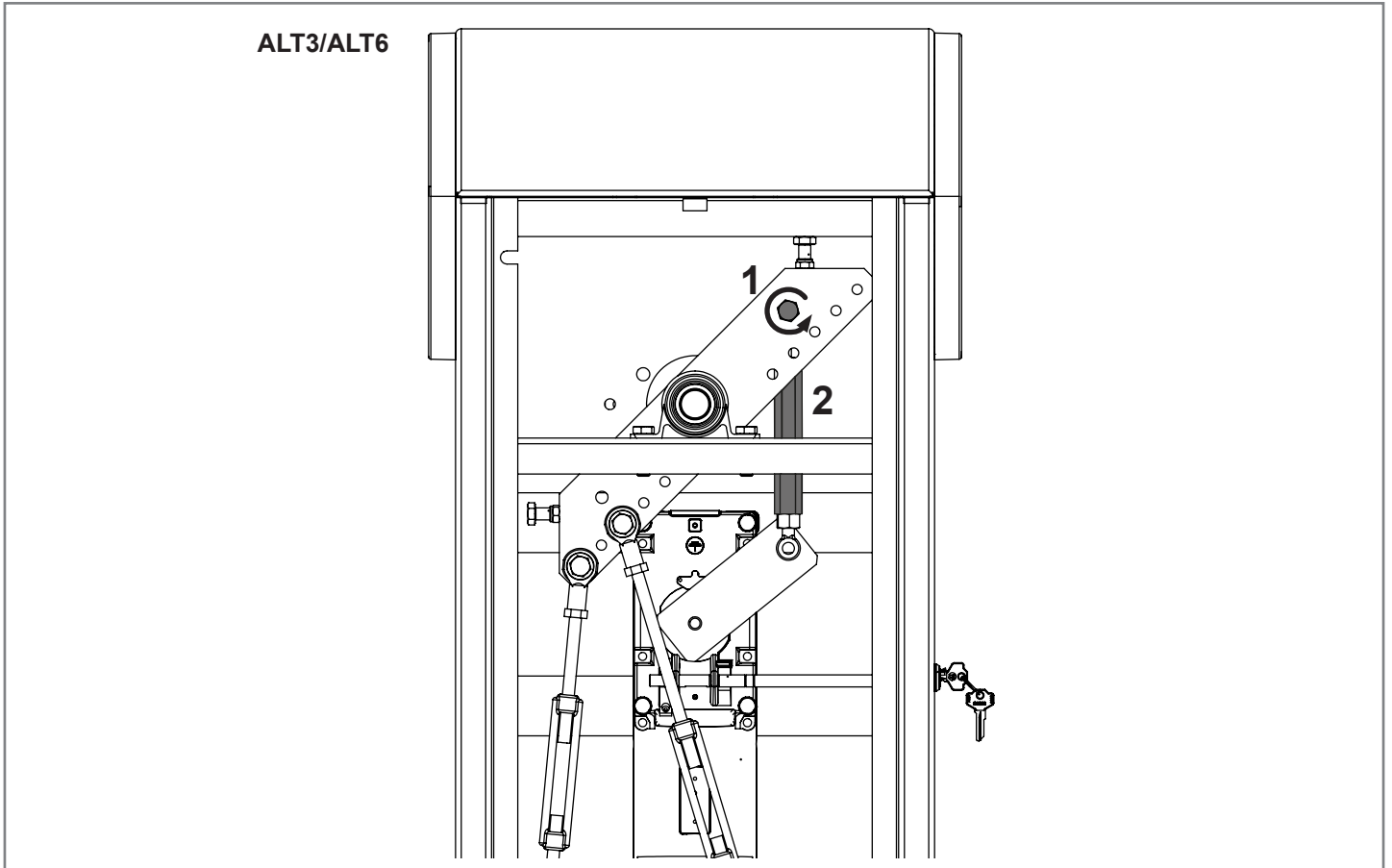

Fig. 10 IT - Rimozione teste a snodo tenditori
 EN - Removal of tensioners articulated joint heads
 FR - Dépose têtes articulées tendeurs
 ES - Extracción de las cabezas articuladas tensores

DE - Entfernung der Federspanner-Gelenkköpfe
 PT - Remoção das rótulas dos tensores
 PL - Demontaż głowic przegubowych i napinaczy

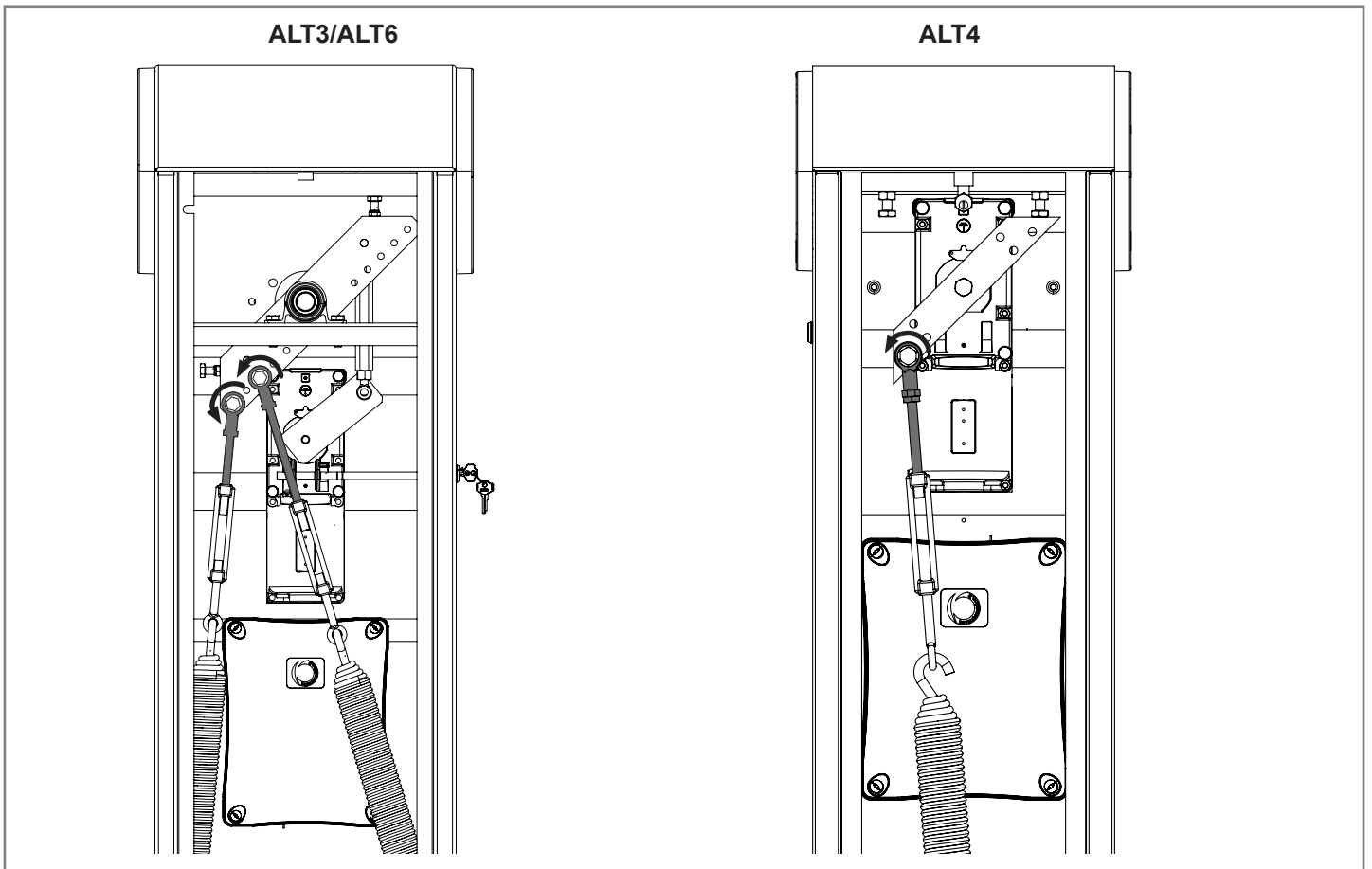

Fig. 11 IT - Inversione fasatura leva bilanciamento
 EN - Balancing lever timing reversal
 FR - Inversion de phase levier d'équilibrage
 ES - Inversión sincronización palanca de equilibrado

DE - Umkehr Einphasung Ausgleichshebel
 PT - Inversão e regulação da alavanca de balanceamento
 PL - Odwrócenie fazowania dźwigni wyważającej

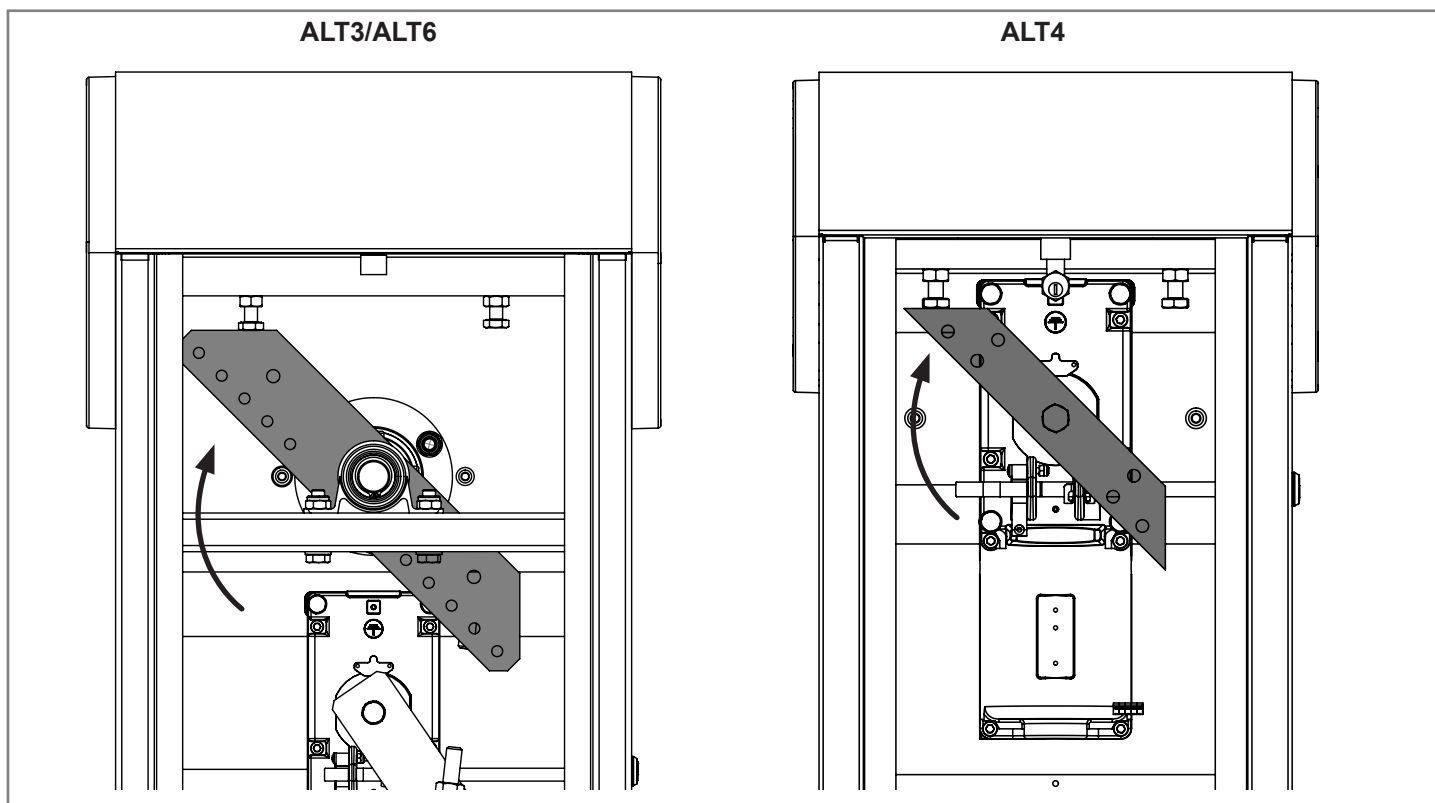

Fig. 12 IT - Ripristino ancoraggi fasatura invertita
 EN - Resetting of reversed timing anchors
 FR - Repose ancrages phase inversée
 ES - Restablecimiento de los anclajes de sincronización invertida

DE - Instandsetzung der Verankerungen umgekehrte Einphasung
 PT - Reposicionamento das ancoragens e regulação invertida
 PL - Montaż kotwien odwróconego fazowania

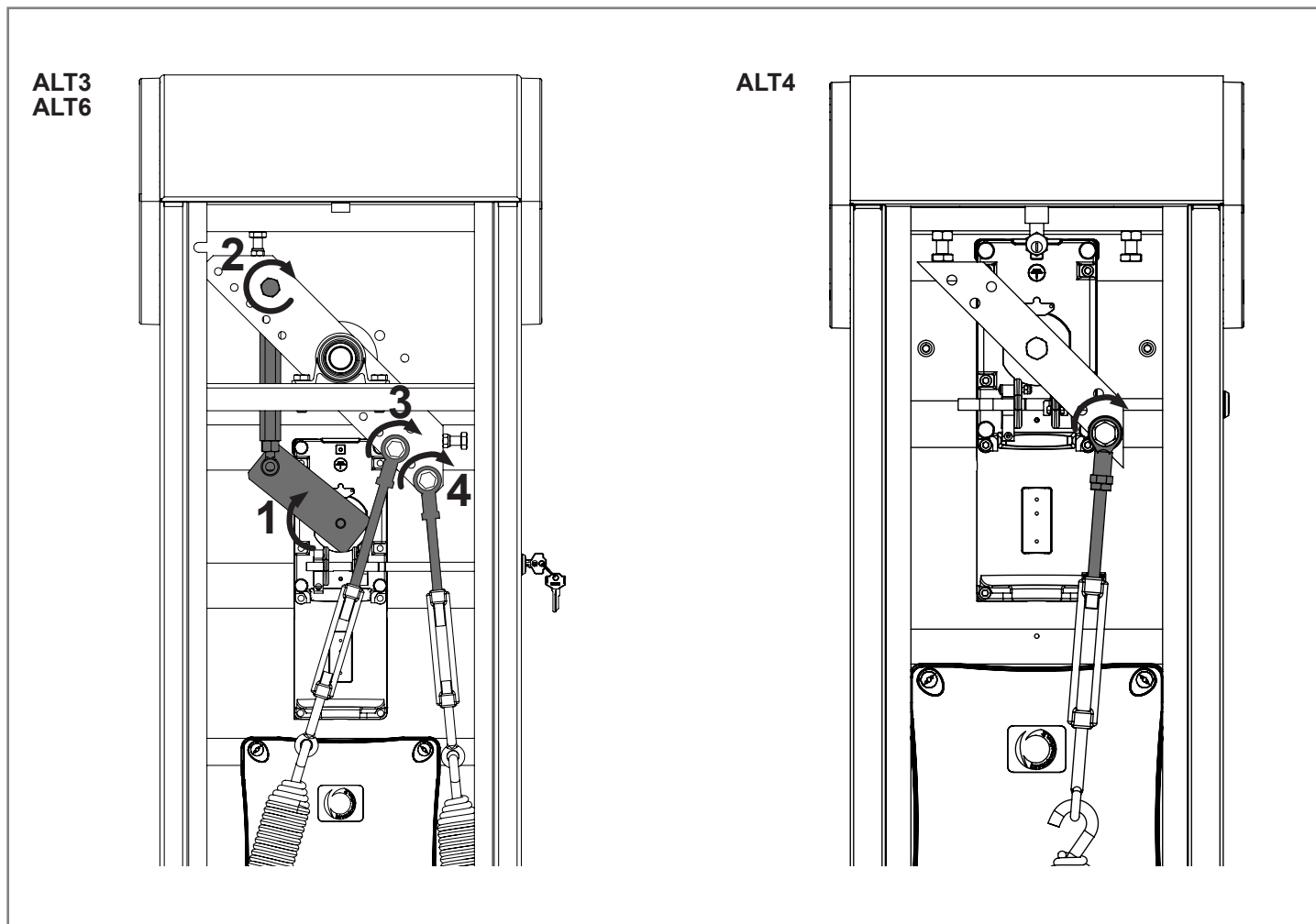
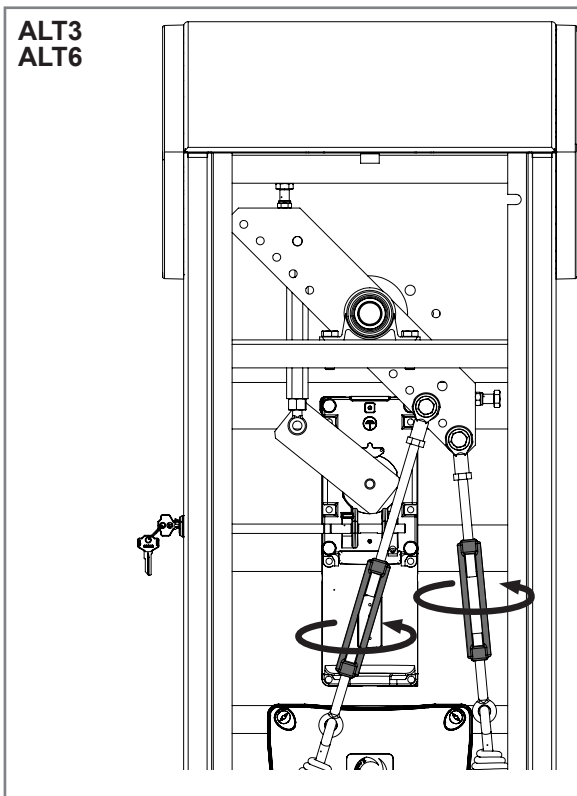

Fig. 13 IT - Ripristino molle
 EN - Spring resetting
 FR - Repose ressorts
 ES - Restablecimiento de los muelles

DE - Instandsetzung der Federn
 PT - Recolocação das molas
 PL - Montaż sprężyn



ALT4

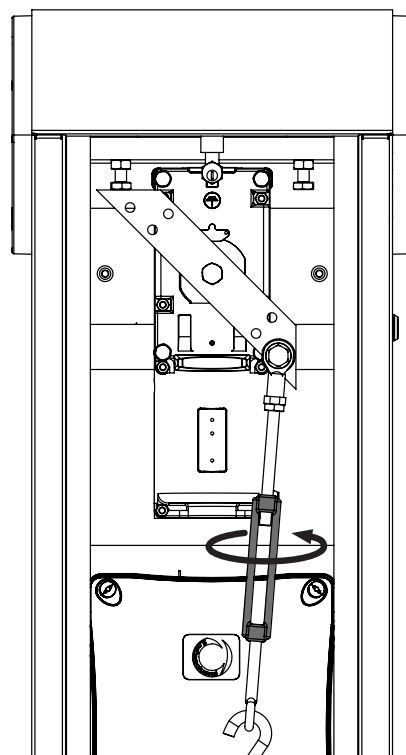
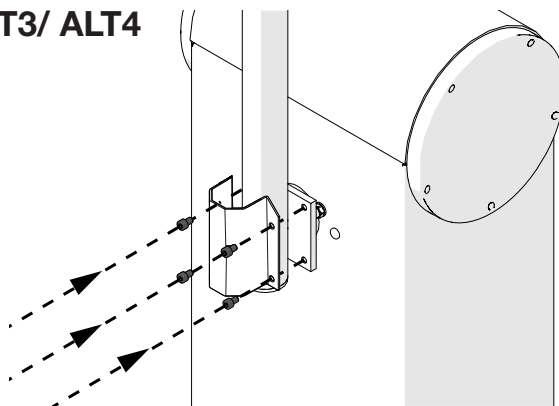

Fig. 14 IT - Fissaggio asta
 EN - Bar fixing
 FR - Fixation lisse
 ES - Fijación del mástil

DE - Befestigung des Schrankenbaums
 PT - Fixação da haste
 PL - Montaż ramienia

ALT3/ ALT4



ALT6

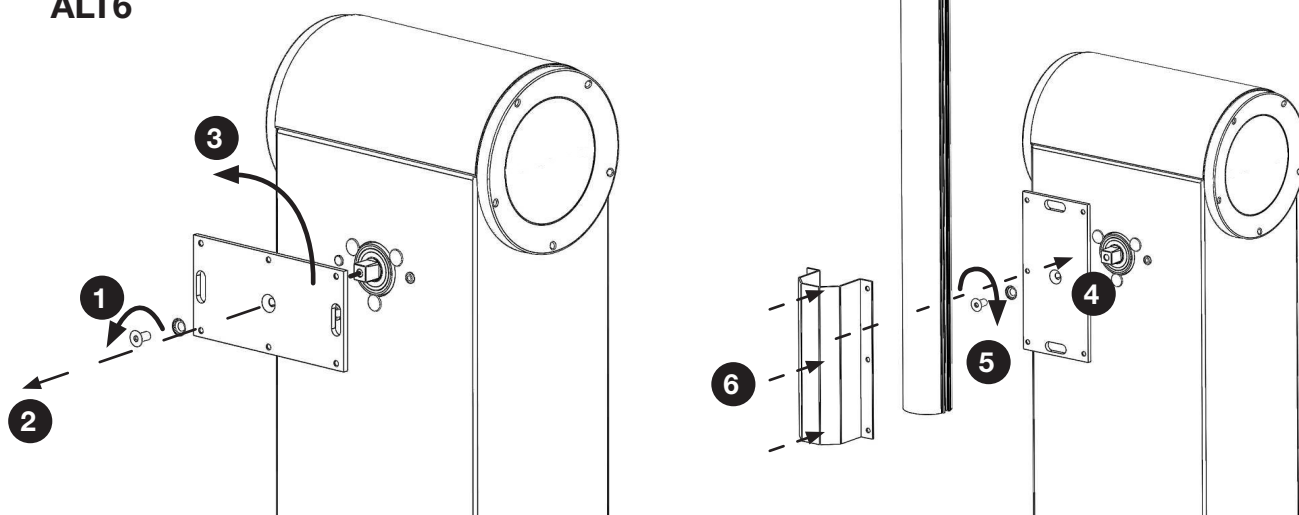

Fig. 15 IT - Sblocco dell'asta
EN - Bar release
FR - Débrayage lisse
ES - Desbloqueo del mástil

DE - Entriegelung des Schrankenbaums
PT - Desbloqueio da haste
PL - Odblokowanie ramienia

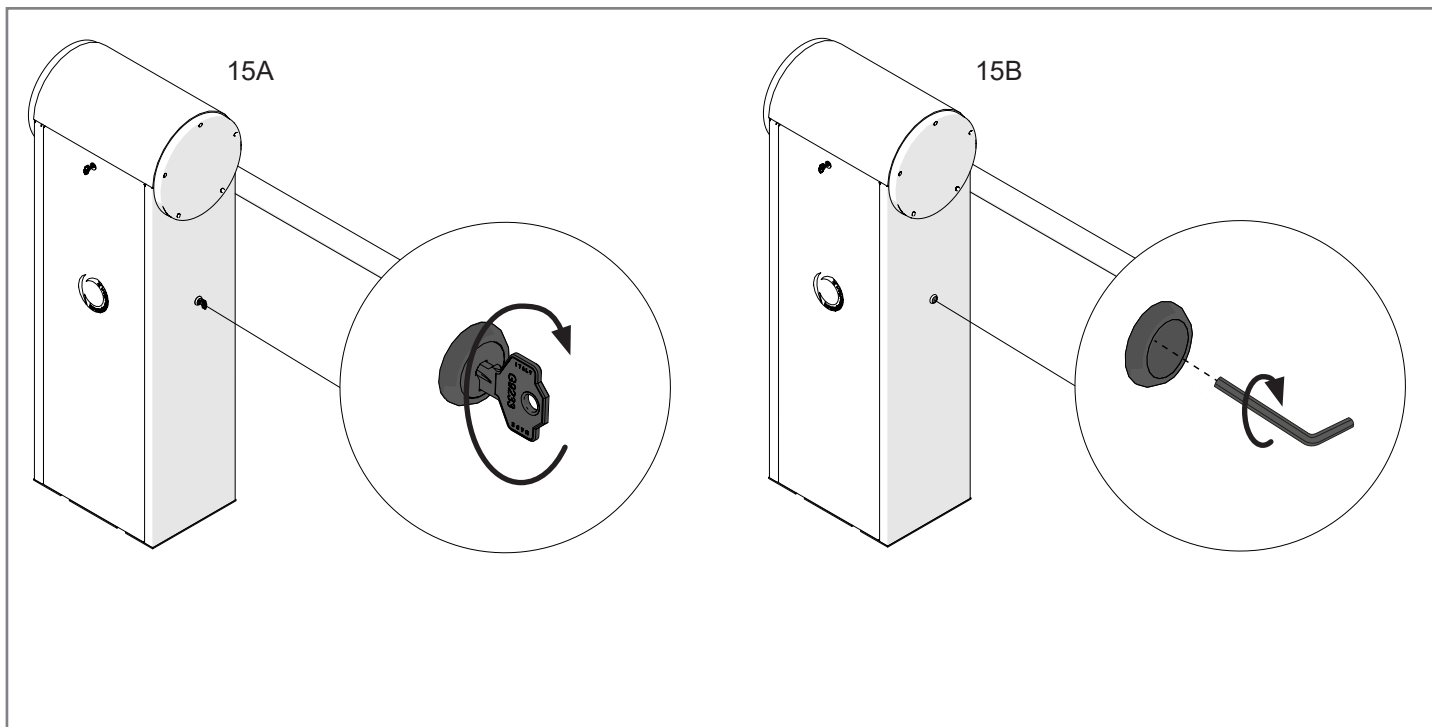

Fig. 16 IT - Regolazione angolatura dell'asta
EN - Bar angle adjustment
FR - Réglage angle lisse
ES - Regulación del ángulo del mástil

DE - Einstellung des Schrankenbaumwinkels
PT - Regulação do ângulo da haste
PL - Regulacja kąta ramienia

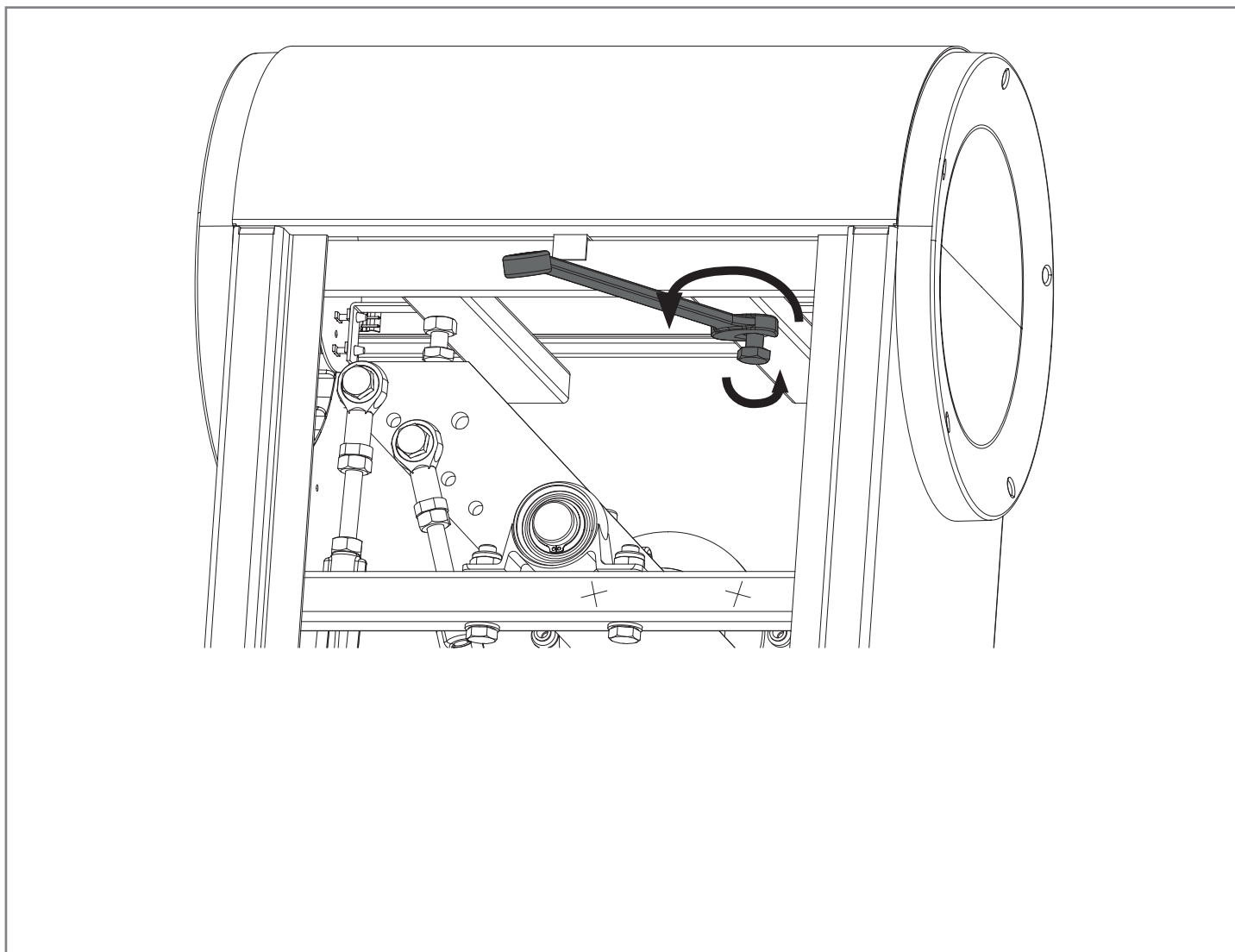
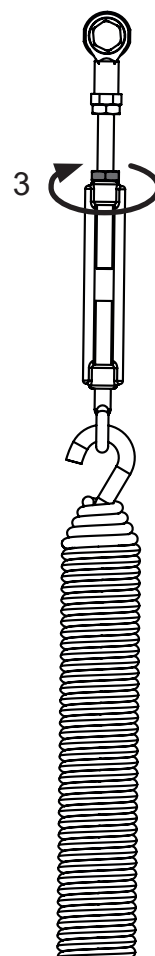
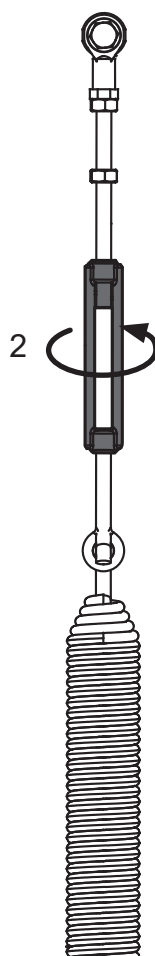
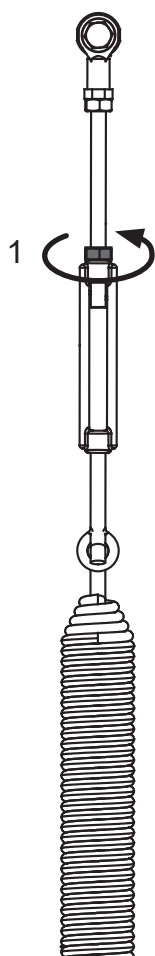
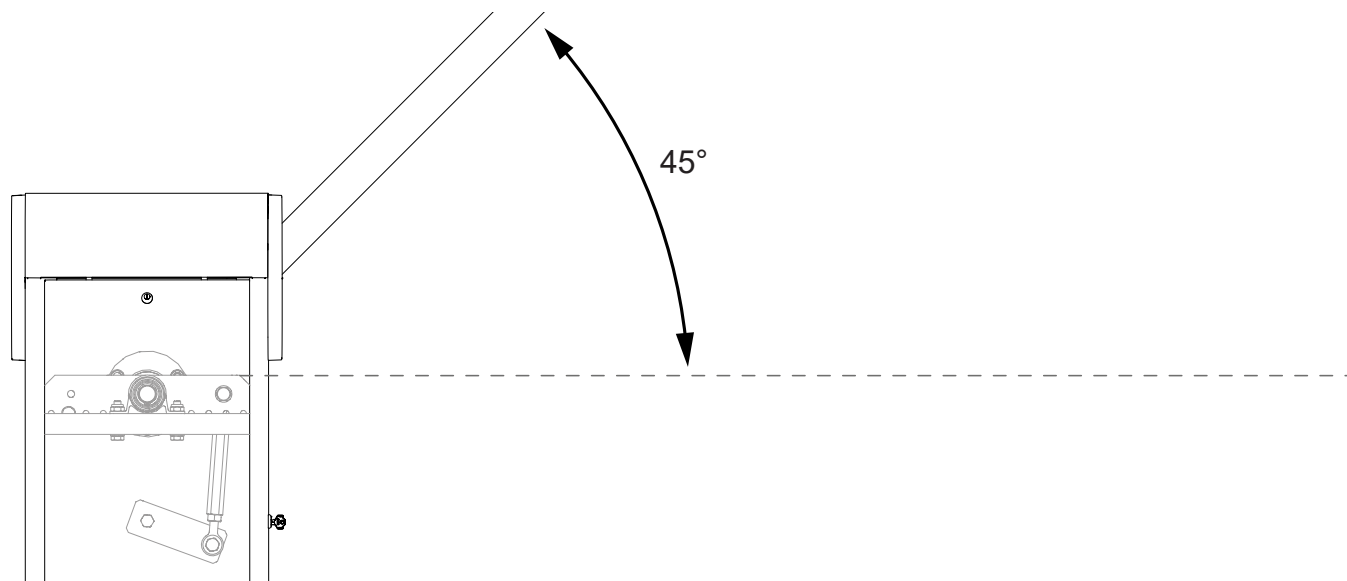

Fig. 17 IT - Bilanciamento asta
EN - Bar balancing
FR - Équilibrage lisse
ES - Equilibrado del mástil

DE - Ausgleichen des Schrankenbaums
PT - Balanceamento da haste
PL - Wyważanie ramienia



DICHIARAZIONE DI CONFORMITA'

DECLARATION OF CONFORMITY

Il sottoscritto Nicola Michelin, Amministratore Delegato dell'azienda
The undersigned Nicola Michelin, General Manager of the company

Key Automation srl, via Meucci 23, 30027 San Donà di Piave (VE) – ITALIA

dichiara che il prodotto tipo:
declares that the product type:

ALT
Barriera elettromeccanica con doppio lampeggiante a LED per asta da 3 a 8 m
Electromechanical barrier with double LED flashing light, bar from 3 to 8 m

Models:
Models:

ALT324KF, ALT424K, ALT624K

E' conforme a quanto previsto dalle seguenti direttive comunitarie:
Complies with the following community (EC) regulations:

Direttiva macchine / Machinery Directive 2006/42/EC
Direttiva compatibilità elettromagnetica / EMC Directive 2014/30/EU
Direttiva bassa tensione / Low voltage Directive 2014/35/EU
Direttiva radiofrequenza / RED Directive 2014/53/EU
Direttiva RoHS / RoHS Directive 2011/65/EU

Secondo quanto previsto dalle seguenti norme armonizzate:
In accordance with the following harmonized standards regulations:

ETSI EN 301 489-1 V2.1.1, ETSI EN 301 489-3 V2.1.1
ETSI EN 300 220-1 V3.1.1, ETSI EN 300 220-2 V3.2.1
EN 55014-1:2017/A11:2020
EN 62233:2008
EN 60335-1:2012/A2:2019, EN 60335-2-103:2015
EN IEC 61000-3-2:2019+A1:2021, EN 61000-3-3:2013+A2:2021
EN 61000-6-2:2019, EN IEC 61000-6-4:2019
EN 62368-1:2014

Dichiara che la documentazione tecnica pertinente al prodotto è stata redatta conformemente a quanto previsto dalla direttiva 2006/42/CE Allegato VII parte B e verrà fornita a fronte di una richiesta adeguatamente motivata dalle autorità nazionali.
Declares that the technical documentation is compiled in accordance with the directive 2006/42/EC Annex VII part B and will be transmitted in response to a reasoned request by the national authorities.

San Donà di Piave (VE), 30/05/22

Amministratore Delegato
General Manager
Nicola Michelin



Key Automation S.r.l.
Via Meucci
30027 San Donà di Piave (VE)
P.IVA 03627650264 C.F. 03627650264
info@keyautomation.it

Capitale sociale 154.000 € i.v.
Reg. Imprese di Venezia 03627650264
REA VE 326953
<http://www.keyautomation.com/>



Organizzazione con sistema di gestione certificato

Key Automation S.r.l.

Via Meucci 23 - 30027 San Donà di Piave (VE)

T. +39 0421 307456 - info@keyautomation.it

www.keyautomation.com

Instruction version

580ALTF REV.09